UCI CYCLING REGULATIONS

PART 3 TRACK RACES

(version on 01.01.05)

TABLE OF CONTENTS

	Page
Chapter I ORGANISATION	1
Chapter II TRACK RACES	2
§ 1 General observations	2
§ 2 The 200 metres Time Trial	5
§ 3 Sprint	5
§ 4 Individual pursuit	10
§ 5 Team pursuit	13
§ 6 Kilometre and 500 metres Time Trial	16
§ 7 Points race	17
§ 8 Keirin	20
§ 9 Team sprint	24
§ 10 Madison	26
§ 11 Scratch	29
§ 12 Tandem	30
§ 13 Motor-pacing	31
§ 14 Elimination race	34
§ 15 Six-day races	34
Chapter III UCI TRACK INDIVIDUAL CLASSIFICATION	37
Chapter IV UCI WORLD TRACK CUP	41
Chapter V WORLD RECORDS	45
Chapter VI EQUIPMENT AND INFRASTRUCTURE	50
§ 1 Starting blocks	50
§ 2 Motorbikes for motor-pacing	50
§ 3 Mopeds	53
§ 4 Attire of motor-pacers	55
§ 5 Attire of moped pacers	56
§ 6 Velodromes	57

UCI CYCLING REGULATIONS

Chapter VII TRACK TEAMS	64
§ 1 Identity	64
§ 2 Legal and Financial Status	65
§ 3 Registration with UCI	65
§ 4 Teams and Riders	66
§ 5 Contract of Employment	67
§ 6 End of Contract	67
§ 7 Dissolution of a Track Team	67
§ 8 Penalties	67
§ 9 UCI Model Contract Between a Rider and a Track Team	68
Chapter VIII CALENDAR	71
Appendix 1 Request of world record homologation	73

UCI CYCLING REGULATIONS**PART 3 TRACK RACES***(version on 01.01.05)***Chapter ORGANISATION****Race Programme**

3.1.001 (N) An organiser shall establish a programme each time he holds a race.

3.1.002 (N) The programme shall include at least the following details of the organisation:

- mention of the fact that the race will be run under UCI Regulations
- possibly giving the specific regulations of the race
- the race programme and schedule
- a description of the track (length, coating, indoor or outdoor.)
- location of the Race Headquarters, the drug-test room and the Press room
- the place and time of the enrolment check and the distribution of riders' numbers
- the place and time of the meeting of Team Managers
- the programme for the official ceremonies
- prizes
- the composition of the Commissaires Panel
- the name, address and telephone number of the director of the organisation
- specification that only the UCI Scale of Penalties shall apply
- the drug-test regulations that are to apply

Secretariat

3.1.003 (N) The organiser shall, for the full duration of the race provide a permanent equipped secretariat in the cycling stadium. A representative of the organiser shall be on hand there at all times.

3.1.004 (N) The Race Headquarters shall be maintained until the results have been transmitted to the UCI or, if the commissaires have not yet finished their work, until such time as they have finished.

3.1.005 (N) The Race Headquarters shall be equipped with a telephone, a fax machine and a photocopier.

Results

3.1.006 (N) As soon as results of the race are known, the organiser shall immediately transmit them by fax to the UCI and to its National Federation, together with the list of riders having taken the start.

3.1.007 (N) The National Federation of the organiser shall without delay communicate to the UCI any changes made to the results communicated by the organiser.

UCI CYCLING REGULATIONS

Security

- 3.1.008** Notwithstanding any legal and administrative provisions that may apply and the duty of each individual to take all due care, the organiser shall ensure that the track, the cycling stadium and all installations are in good condition and do not constitute a danger to security.

For an international event, the UCI may require additional facilities or measures, without that the absence of such a request would engage its responsibility.

(text modified on 26.08.04).

- 3.1.009** The number of riders on track shall in no case exceed:
20 (15 teams for Madison) on a 200 m track
24 (18 teams for Madison) on a 250 m track
36 (20 teams for Madison) on a 333.33 m track

(text modified on 1.01.03).

- 3.1.010** In no case, can the UCI be held responsible for any defects or any mishaps that may occur.

(text modified on 1.01.03).



Chapter TRACK RACES



General observations

Participation

- 3.2.001** Track competitions shall be held either:
- for Juniors
 - or
 - for all other riders together or by category

Conduct of riders

- 3.2.002** Riders shall refrain from any collusion, manoeuvre or movement likely to hinder the conduct or distort the result of the race.

- 3.2.003** If riders wearing the same team clothing ride in the same race, they shall bear some item to distinguish them.

(text modified on 1.01.02).

- 3.2.004** Other than when prevented by circumstances beyond their control, all riders qualifying for repechages or the following round of the competition must participate or else they will be disqualified.

UCI CYCLING REGULATIONS

3.2.005 Riders may carry no object on them or on their bicycles that could drop onto the track. They may not bear or use on the track any radio communication system.

3.2.006 A rider may not have the race stopped because of some irregularity of which he considers himself the victim.

3.2.007 Unless otherwise provided, any rider having fallen or left the track to dismount from his bicycle, may accept help in remounting. He shall resume the race at the point where he left the track.

3.2.008 Riders may not ride on the blue band unless done involuntarily.

(text modified on 1.01.02).

Riders' numbers

3.2.009 (N) riders shall bear two number panels, save in the following specialities where they shall bear just one: the Km Time Trial, the 500 m Time Trial, the Individual Pursuit, the Team Pursuit and the Team Sprint.

(text modified on 1.01.02).

Commissaires Panel

3.2.010 The composition of the Commissaires Panel is indicated in Article 1.2.109.

Judge-Referee

3.2.011 (N) The President of the Commissaires Panel shall appoint one of the panel as judge-referee. He may not carry out the task himself. The presence of a judge-referee shall be compulsory for the sprint, the keirin, the points race and the madison.

The judge-referee shall solely monitor the conduct of riders in the race and their conformity with the racing regulations. On this issue he shall, alone and immediately, impose penalties and take any other decision required under the regulations.

(text modified on 4.07.03).

3.2.012 The judge-referee shall take up a place on the outside of the track in a calm and isolated area with a good general view across the whole track. He must be provided with a means of communicating directly with the President of the Commissaires Panel. At the World Championships, the Olympic Games and World Cup events, the judge-referee shall also have access to a video system permitting slow-motion replay in order to review events in the race. A technician shall be specifically appointed to assist him and operate the video system under his instructions.

UCI CYCLING REGULATIONS

Warning - disqualification

- 3.2.013** Any offence not specifically penalised and any unsporting behaviour shall be punished by a warning, **indicated by a yellow flag**, or by disqualification from the race, **indicated by a red flag**, according to the gravity of the fault, notwithstanding the fine provided for in article 12.1.007. **A rider receives only one warning before disqualification. On each occasion the commissaires will indicate at the same time the race number of the faulting rider. The warning and disqualification are relative to one specific competition only.**

(text modified on 26.08.04).

- 3.2.014** [abrogated on 26.08.04].

Time-keeping

- 3.2.015** (N) Times shall be taken to the thousandth of a second whenever the time determines the result.

Start

- 3.2.016** The starter, located on the track centre, shall give the start by means a pistol shot. In cases where the start is to be taken from a starting block, the following procedure shall apply: the brakes of the machine shall be released by the electronic system that simultaneously triggers the chronometer. Once the bicycle has been fixed, a clock placed before the rider, counts down the last 50 seconds before the start.

- 3.2.017** Any rider holding up the start for reasons not accepted by the starter shall not be permitted to start.

Stoppage

- 3.2.018** The starter alone shall judge whether to stop the race in case of a false start.

- 3.2.019** Stoppage of the race shall be indicated by a double pistol shot, except for the following races: kilometre and 500 metres time trial.

(text modified on 1.01.02).

- 3.2.020** [abrogated on 4.07.03].

Recognised mishap

- 3.2.021** The following shall be considered recognised mishaps:

- a fall
- a puncture
- the breakage of an essential part of the bicycle.

All others incidents are considered un-recognised mishaps.

(text modified on 1.01.02).

UCI CYCLING REGULATIONS

§ 2 The 200 metres Time Trial

Definition

3.2.022 A "200 metres Time Trial" shall take a flying start from the 200 metres line and shall be used to select the participants and rankings for the sprint competition.

(text modified on 1.01.02).

Racing procedure

3.2.023 Riders shall take the start in the order determined by the commissaires.

3.2.024 The rider shall enter the track as soon as he has been passed by the previous rider who has triggered the timing device.

(text modified on 1.01.02).

3.2.025 The rider shall build up speed over a distance depending on the length of the track:

- 250 metres track or smaller: 3.5 laps
- 285,714 metre tracks: 3.0 laps
- 333,33 metre track: 2.5 laps
- 400 metres track and longer: 2.0 laps.

3.2.026 [abrogated on 1st January 2002].

3.2.027 In case of dead heat, riders concerned will be classified by drawing lots.

3.2.028 In the case of a mishap, the rider shall take a new start. Only one new start will be permitted.

(text modified on 1.01.02; 1.01.04).

§ 3 Sprint

Definition

3.2.029 The sprint is a race between 2 to 4 riders over 2 or 3 laps.

(text modified on 4.07.03).

Organisation of the competition

3.2.030 The competition shall be organised according to the table in article 3.2.050.

3.2.031 [abrogated on 1st January 2002].

3.2.032 During World Cup competitions, 16 riders shall qualify for the sprint tournament.

(text modified on 26.08.04).

UCI CYCLING REGULATIONS

3.2.033 *During World Championships, 16 riders shall participate in the sprint tournament.*

Prior to the first round a qualifying 200 m time trial shall be run to determine the fastest 16 riders taking part to the sprint tournament and the make up of the heats. The first 8 riders to have been classified in the Sprint Championships the preceding year shall start last, in the inverse order of classification. The other riders shall start in an order determined by drawing lots.

(text modified on 26.08.04).

Sprint Race

3.2.034 [abrogated on 1st January 2002].

3.2.035 On tracks of less than 333.33 metres, races shall be ridden over 3 laps. On tracks of 333.33 metres or more, races shall be ridden over 2 laps.

(text modified on 1.01.03).

3.2.036 Should a rider drop out of a two-up heat, his opponent shall go to the starting line to be declared the winner. He need not cover the distance.

3.2.037 The starting position shall be determined by drawing lots. The rider drawing number 1 shall start on the inside of the track.

In two-heat races, the other rider shall take the position on the inside of the track in the second heat.

For the deciding round, a fresh draw shall take place.

(text modified on 1.01.02).

Race procedure

3.2.038 The start shall be given by whistle.

3.2.039 The rider on the inside of the track, unless overtaken, shall lead until reaching the pursuit line on the opposite side of the track. A maximum of two standstills shall be permitted for each race. The maximum period for a standstill shall be 30 seconds following which, the leading rider shall be directed by the starter to continue. If he fails to do so, the starter shall stop the race and declare the other rider the winner of the heat. In a three or four-up race, the race shall be immediately rerun as a two or three-up race, without the relegated rider.

(text modified on 1.01.02; 1.01.04).

3.2.040 [abrogated on 1st January 2002].

UCI CYCLING REGULATIONS

3.2.041 Before the last 200 metre line or the start of the final sprint, riders may avail themselves of the full width of the track but must nevertheless leave sufficient space for their opponent to pass and shall refrain from any manoeuvres that could provoke a collision, a fall or cause any rider to ride off the track.

3.2.042 During the final sprint, even if launched before the last 200 metres, each rider shall remain in his lane up to the finish, unless he has at least a clear cycle-length lead and shall not make any manoeuvre to prevent the opponent from passing.

(text modified on 1.01.02).

3.2.043 A rider may not challenge or pass on the left an opponent riding in the sprinters' lane. If the leading rider leaves the sprinters' lane and his opponent attempts to pass to his left, he may not return to that lane unless he still has a clear cycle-length lead.

3.2.044 A rider passing on the right of his opponent, who is in the sprinters' lane, may not crowd him or cause him suddenly to reduce speed.

3.2.045 A rider starting the sprint outside the sprinters' lane may not drop into that lane if it is already occupied by his opponent unless there is a clear cycle-length lead.

(text modified on 1.01.02).

3.2.046 Should the leading rider drop down below the measuring line he shall be relegated unless he does so involuntarily and unless, at that moment, the result may be considered a foregone conclusion.

3.2.047 If, in a three or four-up race, a rider behaves in an irregular manner to favour another rider, he shall be relegated. The race shall be immediately rerun as a two or three-up race.

(text modified on 1.01.02).

Race stoppages

3.2.048 The race may be stopped only:

1) in the case of fall.

If the fall be intentionally caused by a competitor, that competitor shall be relegated or disqualified from the tournament according to the gravity of the fault committed and the other competitor declared the winner. In three or four-up heats, the race shall be immediately restarted with the remaining two or three riders.

Should the fall have been caused by a competitor riding too slowly in a curve or by any other unintentional fault, the race shall be restarted and the offending rider shall take the inside of the track.

If the fall is not caused by a competitor committing a fault, commissaires shall decide whether the race is to be restarted with the riders in the same order or whether the positions at the time of the fall should be considered final.

2) in the case of a puncture.

3) in the case of the breakage of an essential part of the bicycle.

UCI CYCLING REGULATIONS

In all of these three cases, the commissaires shall decide whether the race is to be restarted with the riders in the same order or whether the positions at the time of the incident should be considered final.

4) in the following cases:

4.a) If a rider loses his balance, falls or touches an opponent or the barrier, the race shall be restarted and the rider in question shall take the inside of the track.

4.b) If the starter observes a flagrant infringement and stops the race before the bell rings to indicate the start of the last lap, the commissaires may relegate or disqualify the rider committing the infringement. The other rider shall be declared the winner or in the case of a three or four-up race, it shall be restarted as a two or three-up race.

(text modified on 1.01.02).

3.2.049 If the rider committing the infringement is not relegated or disqualified, the race shall be restarted and that rider shall take the inside of the track.

(text modified on 1.01.02).

3.2.050 Table of sprint competitions:

UCI CYCLING REGULATIONS

TABLE SHOWING THE COMPOSITION OF SPRINT EVENTS INVOLVING 16 RIDERS

STARTERS	SYSTEM	EVENT	COMPOSITION	1st	2nd
16	1/8 Finales	1	N1 - N16	1A1	
	8 X 2 ⇨ 1 = 8	2	N2 - N15	2A1	
		3	N3 - N14	3A1	
		4	N4 - N13	4A1	
		5	N5 - N12	5A1	
		6	N6 - N11	6A1	
		7	N7 - N10	7A1	
		8	N8 - N9	8A1	
8	1/4 Finales	1	1A1 - 8A1	1C1	
	4 X 2 ⇨ 1 = 4	2	2A1 - 7A1	2C1	
		3	3A1 - 6A1	3C1	
		4	4A1 - 5A1	4C1	
4	1/2 Finales	1	1C1 - 4C1	1D1	
	2 X 2 ⇨ 1 = 2	2	2C1 - 3C1	2D1	
	(in 2 heats, 3 if required)				
4	Finales	1	1D1 - 2D1	1st (gold)	2nd (silver)
	2 X 2 ⇨ 1 = 2	2	1D2 - 2D2	3rd (bronze)	4th
	(in 2 heats, 3 if required)				

(text modified on 26.08.04).

UCI CYCLING REGULATIONS

§ 4 Individual pursuit**Definition**

3.2.051 Two cyclists compete in a fixed distance. The riders start on opposite sides of the track. The winner is determined by either catching the other rider or recording the fastest time.

(text modified on 1.01.02).

Organisation of the competition

3.2.052 Races shall be run over:

- 4 km for Men
- 3 km for Women
- 3 km for Junior Men
- 2 km for Junior Women.

3.2.053 This event shall be organised in two series:

- 1) The qualifying rounds to select the best 4 riders on the basis of their times.
- 2) the finals

The riders with the two best times shall ride off in the final for first and second place while the two others shall ride off in the final for third and fourth places.

(text modified on 26.08.04).

3.2.054 [abrogated on 26.08.04].

3.2.055 For the qualifying rounds the commissaires shall make up each match from riders presumed to be of equal ability, but without matching the two presumed to be the best.

3.2.056 During the qualifying rounds account shall be taken solely of times.

If a rider is caught he must finish the distance to have a time recorded.

A caught rider may not take pace from his opponent, nor pass him, on pain of disqualification.

3.2.057 In a race between two of the four best riders (finals), if one rider catches the other the race is deemed to have finished.

3.2.058 A rider is considered to have been caught at the point that the chainset on his opponent's bicycle draws level with that on his own bicycle.

3.2.059 [abrogated on 26.08.04].

3.2.060 Should a rider fail to take the start of a final, his opponent is declared the winner.

A rider failing to start the final for 1st and 2nd places shall be placed 2nd; a rider failing to start the

UCI CYCLING REGULATIONS

final for 3rd and 4th places shall be placed 4th. If the reason for failing to ride is not accepted, the absent rider shall be disqualified and his place shall remain vacant.

- 3.2.061** In the event that riders record the same times to the closest thousandth of a second, the rider who records the best time for the final lap shall be declared the winner.

Preparation of the track

- 3.2.062** The blue bands shall be made impassable round the bankings by the placing every 5 metres of 50 cm long pads of a synthetic material.

- 3.2.063** At the start the two riders shall be positioned at diametrically opposite points on the track.

- 3.2.064** The starting point in front of the main stand shall be marked by a red disc. The starting point in the back straight shall be marked by a green disc.

- 3.2.065** (N) At each finishing point a device shall be set up to record the time of each rider and trigger a green light and a red light to indicate the passing of the respective riders.

- 3.2.066** A lap counter and a bell shall be set up at each rider's finish line.

- 3.2.067** (N) The order of passing, the number of laps completed, the time of each rider and the difference in time between the two riders on each half-lap and the final time of each rider will be displayed on the electronic scoreboard.

- 3.2.068** On tracks whose size is such that the distance to be ridden does not comprise a complete number of laps, the point of the first kilometre ridden shall be marked by a red pennant for the rider who starts from the red disc and a green pennant for the rider starting from the green disc. The beginning of the final kilometre shall be marked by two red pennants and two green pennants respectively. In competitions for Junior Women the first and last half-kilometres shall be marked.

- 3.2.069** (N) At the start, each rider shall be held in a starting block.

Race procedure

- 3.2.070** The start shall be taken on the inside edge of the track.

- 3.2.071** Riders starting point:
a) for the qualifying rounds the commissaires shall determine the starting point for each rider.
b) in the final, the rider who has in the qualifying round recorded the best time shall finish in front of the main grandstand.

(text modified on 1.01.02; 26.08.04).

- 3.2.072** The starter shall stop the race with a double pistol shot in the event of a false start. The course will then be restarted.

UCI CYCLING REGULATIONS

3.2.073 A pistol shot shall mark the end of the race at the moment on which each rider crosses his finish line at full distance or, in the races covered by article 3.2.057, at the moment that one rider catches the other.

Mishaps

3.2.074 Qualifying rounds:

In the first half-lap, in the event of a mishap, the race is stopped and restarted immediately.

After the first half-lap the race shall not be stopped. A rider who is the victim of a mishap shall be permitted to ride again at the end of the qualifying rounds (either alone against the watch or matched against another rider in the same situation).

A rider may be only permitted to have 2 starts.

(text modified on 1.01.02; 1.01.04).

3.2.075 Finals:

In the event of a mishap in the first half-lap, the race shall be stopped. It shall be restarted immediately by both riders.

In the event of a mishap before the final kilometre (half-kilometre for Junior Women) the race is interrupted and the riders shall restart from their positions within a maximum period of 5 minutes:

- the leading rider on the line of the last half-lap which he completed
- the other rider shall start at a distance before the opposite line calculated by the Commissaires Panel on the basis of the time that he was behind at his last completed half-lap
- the riders shall ride the distance remaining as at the last completed half-lap before the mishap.

The final time shall be obtained by adding the partial times.

Inside the final kilometre (half-kilometre for Junior Women):

If the leading rider suffers a mishap, the result shall stand and he shall be declared the winner. The average speed at the last completed half-lap shall be used to calculate the final time to be awarded.

(text modified on 1.01.02; 1.01.04; 26.08.04).

3.2.076 In each round, including the final, only one new start may be permitted as a result of mishaps.

(text modified on 1.01.02).

3.2.076

bis [abrogated on 1st January 2002].

UCI CYCLING REGULATIONS

§ 5 Team pursuit**Definition**

3.2.077 Two teams compete against each other in a 4 km race starting on each side of the track. The winner is determined by either catching the other team or recording the fastest time.

(text modified on 1.01.02).

Organisation of the competition

3.2.078 Except for the specific details (even implicit) in this sub-section, the rules of the individual pursuit shall apply equally to the team pursuit.

3.2.079 Teams shall be made up of riders entered for this event. The composition of the team may vary from one race to another.

The team manager must notify the commissaires of any changes at least one hour before each start.

(text modified on 1.01.02).

3.2.080 The time and the classification of each team shall be taken on that of the third rider of each team. The time shall be measured on the front wheel of the third rider of each team.

(text modified on 1.01.02; 1.01.03).

3.2.081 A team is caught when the opposing team (at least 3 riders riding together) arrives at or within a distance of one metre of it.

3.2.082 Qualifying rounds shall be organised to find the 4 best teams.

(text modified on 1.01.02; 26.08.04).

3.2.083 On tracks of less than 400 metres, each team shall ride alone against the clock. On other tracks the commissaires shall make up each match from teams presumed to be of equal ability, but without matching the two presumed to be the best.

3.2.084 [abrogated on 1.01.02].

3.2.085 This event shall be organised in two phases:

- 1) The qualifying heats to select the 4 best teams on the basis of their times;
- 2) The finals.

The teams having made the two best times shall ride off the final for first and second places, the two others shall ride off the final for third and fourth places.

(text modified on 1.01.02; 26.08.04).

UCI CYCLING REGULATIONS

3.2.086 If one team is caught by the other during the finals, the race is over and the catching team shall be declared the winner.

3.2.087 [abrogated on 26.08.04].

3.2.088 Should a team fail to start in the finals, its opponents shall be declared winners.

A team failing to start the final for 1st and 2nd places shall be placed 2nd; a team failing to start the final for 3rd and 4th places shall be placed 4th. If the reason for failing to ride is not accepted, the absent team shall be disqualified and his place shall remain vacant.

3.2.089 Situations of teams not starting and ties on time shall be decided in accordance with the regulations for the individual pursuit.

If it is necessary to place teams who fall into several of the following categories, the classification shall be drawn up as follows, in decreasing order from the 8th place:

- teams who fail to start (article 3.2.087), then
- teams who have caused two false starts (article 3.2.095), then
- teams relegated for pushing (article 3.2.096), then
- teams left incomplete after mishaps (article 3.2.100), then
- teams caught (article 3.2.085).

(text modified on 1.01.02).

Preparation of the track

3.2.090 (N) An electronic timing strip shall be set up on the pursuit lines in order to judge the finish of the front wheel of the third rider of each team.

(text modified on 1.01.02).

3.2.091 The timing and recording of half-laps completed shall be made on the front wheel of the first rider.

Race procedure

3.2.092 The riders of each team shall start either side by side or staggered at an angle of 45° behind the start line. The distance between riders shall be one metre.

3.2.093 (N) The rider on the inside of the track shall be held by a starting block. This rider must lead until the first relay.

(text modified on 1.01.02).

3.2.094 The starter shall stop the race for a false start by a double pistol shot, for example, one of the riders anticipates the start or if the rider on the inside of the track fails to take the lead.

(text modified on 1.01.02).

UCI CYCLING REGULATIONS

3.2.095 A team which causes two false starts in the qualifying round shall be eliminated.

A team which causes two false starts during the finals, loses its final.

(text modified on 1.01.02; 26.08.04).

3.2.096 Pushing between members of the same team is strictly forbidden on pain of disqualification in the qualifying rounds. During the finals, that team loses its finals.

(text modified on 1.01.02; 26.08.04).

3.2.097 When the commissaires see that a team is about to be caught, they shall, in order to avoid a collision with the other team or hinder its progress, signal to the former team with a red flag that it may not effect any more relays and remain at the bottom of the track until the opposing team has passed.

Any failure to act on this instruction shall result in the immediate disqualification of the team.

(text modified on 1.01.02).

3.2.098 The race shall be over at the moment that the third rider of each team crosses the finishing line for the final time at full distance or, in the finals, at the point that one team (at least 3 riders riding together) catches the other team.

(text modified on 1.01.02).

Mishaps

3.2.099 During the qualifying round:

During the first half-lap, if any team suffers a mishap the race shall be restarted immediately.

If a mishap occurs after the first half-lap and only one rider is involved, the team may either continue with 3 riders, or stop. If the team chooses to stop, it must do so within one lap of the place of the mishap or they face disqualification. Where practicable, the other team shall continue.

The team which has stopped following a mishap shall restart **alone against the watch** at the end of the qualifying rounds.

If a team suffers a mishap during its subsequent ride, it shall continue with 3 riders or be disqualified.

In each round, including the final, only one new start may be permitted as a result of mishaps.

(text modified on 1.01.02; 1.02.03; 1.01.04; 26.08.04).

UCI CYCLING REGULATIONS

3.2.100 During the finals:

In the event of a mishap in the first half-lap, the race shall be stopped and restarted. If the team suffers a further mishap during its subsequent ride, it shall be eliminated.

After the first half-lap no mishap will be taken into consideration. The team shall continue if they still have three riders on the track.

Otherwise this team must stop and will be considered beaten.

In each round, including the final, only one new start may be permitted as a result of mishaps.

(text modified on 1.01.02; 26.08.04).

§ 6 Kilometre and 500 metres Time Trial

Definition

3.2.101 The race known as the «kilometre» or «500 metres» race respectively is an individual time trial race with a standing start.

3.2.102 During the World Cup and World Championships, this race is run over a distance of 1000 metres for men and 500 metres for women.

Organisation of the competition

3.2.103 *At the World Championships, each participant shall take the track alone.*

3.2.104 The starting order shall be set by commissaires.

3.2.105 During World Championships the first 10 riders from the World Championships of the preceding year shall set out last in the inverse order of their placings. The starting order of the other riders shall be determined by drawing lots.

3.2.106 The races shall be ridden directly as a final.

3.2.107 In the case of a draw for the three best times, an identical medal shall be awarded to each rider concerned.

3.2.108 All competitors must ride the course at the same meeting. If it is not possible for all the participants to ride this race, for example because of atmospheric conditions, the entire race shall be rerun at the following meeting and no account shall be taken of the times previously made.

Race procedure

3.2.109 The blue band shall be rendered impracticable in the bends by pads of synthetic material 50 cm long, placed at 5 metre intervals.

3.2.110 (N) The rider shall be held at the start by a starting block.

UCI CYCLING REGULATIONS

3.2.111 The start shall be taken on the inside edge of the track.

3.2.112 In the case of a false start the rider shall restart immediately.

In the case of a mishap, the rider shall take a new start after a rest of approximately 15 minutes.

A rider may be only permitted to have a total of 2 starts.

(text modified on 1.01.02; 1.01.04).

3.2.113 [abrogated on 1st January 2002].

§ 7 Points Race

Definition

3.2.114 The Points Race is a speciality in which the final placings are determined according to accumulated points won by riders during the sprints and by taking laps.

(text modified on 1.01.02; 1.01.03).

Organisation of the competition

3.2.115 According to the number of riders entered for the speciality, the commissaires may possibly compose qualifying heats and shall determine how many of the best placed riders from each heat are to participate in the final.

3.2.116 On the 250 metres track or shorter, intermediate sprints shall be run off every 10 laps.

On other tracks, intermediate sprints are run off after each number of laps closest to 2 km, that is to say:

- every 7 laps on 285.714 metres tracks
- every 6 laps on 333.33 metres tracks
- every 5 laps on 400 metres tracks

3.2.117 *During World Championships the distances, number of laps and number of sprints shall be the following:*

	<i>Qualifier</i>	<i>Final</i>
<i>Men</i>		<i>40 km</i>
<i>Women</i>		<i>24/25 km</i>
<i>Men junior</i>	<i>15/16 km</i>	<i>24/25 km</i>
<i>Women junior</i>	<i>10 km</i>	<i>20 km</i>

UCI CYCLING REGULATIONS

TRACK LENGTH	MEN		WOMEN		JUNIOR MEN				JUNIOR WOMEN			
	Final		Final		Qualification		Final		Qualification		Final	
	40 km		25 km		15 km		25 km		10 km		20 km	
(In m)	LAPS	SPRINT	LAPS	SPRINT	LAPS	SPRINT	LAPS	SPRINT	LAPS	SPRINT	LAPS	SPRINT
250	160	16	100	10	60	6	100	10	40	4	80	8
TRACK LENGTH	MEN		WOMEN		JUNIOR MEN				JUNIOR WOMEN			
	Final		Final		Qualification		Final		Qualification		Final	
	40 km		24 km		16 km		24 km		10 km		20 km	
(In m)	LAPS	SPRINT	LAPS	SPRINT	LAPS	SPRINT	LAPS	SPRINT	LAPS	SPRINT	LAPS	SPRINT
285,714	140	20	84	12	56	8	84	12	35	5	70	10
333,33	120	20	72	12	48	8	72	12	30	5	60	10
400	100	20	60	12	40	8	60	12	25	5	50	10

(text modified on 1.01.02; 1.01.03).

- 3.2.118** The first rider in each sprint shall be awarded 5 points, the second 3 points, the third 2 points and the fourth one point.

Any rider that gains a lap on the main field is awarded 20 points.

Any rider that loses a lap on the main field is deducted 20 points.

(text modified on 1.01.02; 1.01.03).

- 3.2.119** Where two or more riders are equal on points, the places in the final sprint shall declare the winner.

(text modified on 1.01.02; 1.01.04).

Race Procedure

- 3.2.120** Before the start, half of the riders shall be lined up along the railings, the other half lining up in single file in the sprinter's lane.

- 3.2.121** A flying start shall be taken after one neutralised lap.

- 3.2.122** Sprints shall be run according to the rules governing sprint races.

- 3.2.123** A rider shall be considered to have gained a lap and be awarded 20 points when he has caught up with the rear of the largest bunch.

(text modified on 1.01.02; 1.01.03; 1.02.03).

- 3.2.124** A rider having dropped behind the bunch and having been caught up may not lead, under penalty of disqualification.

UCI CYCLING REGULATIONS

3.2.125 If at the moment of a sprint considered for classification, one or some rider(s) catch up with the main bunch, this (these) rider(s) shall gain a lap and be awarded 20 points. The points awarded for the sprint shall be given immediately to the riders of the break behind or to those ahead of the bunch.

(text modified on 1.01.02; 1.01.03).

3.2.126 Riders having dropped behind the bunch and having been caught up by one or more riders about to gain a lap may not lead these riders, under pain of disqualification.

(text modified on 1.01.02; 1.01.03).

3.2.127 Riders one or several laps down may be withdrawn by the commissaires panel.

(text modified on 1.01.02).

3.2.128 In the event of collusion between riders, the (N) judge-referee may disqualify the riders concerned, possibly after a warning.

3.2.129 In the case of a recognised mishap, the rider shall be entitled to a neutralisation during the number of laps closest to 1300 metres. On returning to the track, he shall resume the position he occupied before the mishap.

(text modified on 1.01.02; 1.01.04).

3.2.130 No neutralisation may be granted in the last five laps.

3.2.131 Should more than half the riders fall, the race shall be stopped and the commissaires shall determine the duration of the interruption. A new start shall be taken from the positions at the moment of the fall.

3.2.132 A rider suffering a recognised mishap in the last five laps may not return to the track but shall nevertheless appear in the final placings depending on the laps won or lost and the points accumulated prior to the mishap.

Other riders not finishing the race shall be excluded from the final placings.

UCI CYCLING REGULATIONS

3.2.133 If the track becomes impracticable to race for any reason, the commissaires shall decide as follows:

DISTANCE	DECISIONS		
	Complete rerun the same day	Resume race with points accumulated	Let results stand
	Stopped before:	Stopped after:	Stopped after:
10 km	8 km	/	8 km
15/16 km	10 km	/	10 km
20 km	10 km	10-15 km	15 km
24/25 km	10 km	10-20 km	20 km
30 km	15 km	15-25 km	25 km
40 km	15 km	15-30 km	30 km

(text modified on 1.01.02; 1.01.03).

§ 8 Keirin

Definition

3.2.134 Riders compete in a sprint after completing a number of laps behind a motorized pacer who leaves the track 600/700 meters before the finish.

(text modified on 1.01.02).

Organisation of the competition

3.2.135 The race shall compose a 1st round, repechages, a 2nd round and a final as shown in the following table:

1st Round			Repechages			2nd Round			
No. of heats	No. of riders per heat	Riders qualified per heat for the 2 nd round	No. of heats	No. of riders	Riders qualified per heat for the 2 nd round	No. of heats	No. of riders	Riders qualified per heat for the final 1-6 places	Riders qualified per heat for the final 7-12 places
4	7	2	4	5	1	2	6	3	3

UCI CYCLING REGULATIONS

TRACK LENGTH	NO. OF LAPS	PACER (No. of laps to the finish)
250	8	2.5
285.714	7	2.5
333.33	6	2
400 + >	5	1.5

(text modified on 1.01.02).

UCI CYCLING REGULATIONS

COMPOSITION EXAMPLE OF KEIRIN EVENTS IN THE WORLD CHAMPIONSHIP AND IN THE OLYMPICS INVOLVING 28 RIDERS

COMPOSITION EXAMPLE OF KEIRIN EVENTS IN THE WORLD CHAMPIONSHIP AND IN THE OLYMPICS INVOLVING 28 RIDERS					
1st ROUND:	Composition:	4 HEATS of 7 riders			
		A	B	C	D
		W1	W2	W3	W4
		W5	W6	W7	W8
		W9	W10	W11	W12
		C4	C3	C2	C1
		C8	C7	C6	C5
		C12	C11	C10	C9
		C16	C15	C14	C13
		Abbreviations: «W» the 12 first riders of the World Championship the year before «C» Ranking in the Keirin General Classification of the World Cup in the current year			
REPECHAGES:	Results:	*QA1	*QB1	*QC1	*QD1
		*QA2	*QB2	*QC2	*QD2
		QA3	QB3	QC3	QD3
		QA4	QB4	QC4	QD4
		QA5	QB5	QC5	QD5
		QA6	QB6	QC6	QD6
		QA7	QB7	QC7	QD7
		*Riders qualified for 2 nd Round (Semi-finals)			
	Composition:	4 HEATS of 5 riders			
		QA3	QB3	QC3	QD3
	QD4	QC4	QB4	QA4	
	QC5	QB5	QA5	QD5	
	QB6	QA6	QD6	QC6	
	QA7	QD7	QC7	QB7	
	Results:	*RA1	*RB1	*RC1	*RD1
	*Riders qualified for 2 nd Round (Semi-finals)				

UCI CYCLING REGULATIONS

COMPOSITION EXAMPLE OF KEIRIN EVENTS IN THE WORLD CHAMPIONSHIP AND IN THE OLYMPICS INVOLVING 28 RIDERS (CONTINUATION)

2 nd ROUND: (Semi-finals)	Composition:	2 HEATS of 6 riders	
		FA	FB
		QA1	QB1
		QD1	QC1
		QB2	QA2
		QC2	QD2
		RA1	RB1
		RD1	RC1
	Results:	*FA1	*FB1
		*FA2	*FB2
		*FA3	*FB3
		**FA4	**FB4
		**FA5	**FB5
		**FA6	**FB6
	*Riders qualified for the FINAL 1 - 6		
	**Riders qualified for the FINAL 7 - 12		

UCI CYCLING REGULATIONS

3.2.136 [abrogated on 1st January 2002].

3.2.137 The pacer shall ride within the sprinter line, starting at 30 kph and shall gradually increase speed to 50 kph which should be achieved at least 4 laps to go (250 m tracks). He shall leave the track as directed by the Commissaires, in principle 600-700 metres before the finish.

For Junior Women and Elite Women the respective speed shall be 25 kph and 45 kph.

(text modified on 1.01.02).

Race procedure

3.2.138 The starting positions of the riders shall be determined by drawing lots. The riders shall be placed side by side in that order on the pursuit line, the sprinters' lane being left free. The riders shall be held, but not pushed, by assistants.

3.2.139 The start shall be given when the pacer approaches the pursuit line in the sprinters' lane. Unless another rider voluntarily takes that position, the rider who drew No.1 shall follow immediately behind the pacer for at least the first lap, failing which the race shall be stopped and that rider eliminated. In the restart, the rider who drew No.2 shall follow immediately behind the pacer.

(text modified on 1.01.02; 1.02.03).

3.2.140 Any rider who passes the rear of the back wheel of the pacer before he leaves the track shall be disqualified.

(text modified on 1.01.02).

3.2.141 The race shall be run according to the Sprint Regulations.

3.2.142 [abrogated on 1st January 2002].

3.2.143 A restart shall take place immediately if a mishap occurs within the first 30 meters.

(text modified on 1.01.02).

§ 9**Team Sprint**

(text modified on 1.01.02).

Definition

3.2.144 The Team Sprint is a race with a series of heats run over three laps of a track by two teams of three riders, each of whose riders shall lead for one lap.

(text modified on 1.01.02).

UCI CYCLING REGULATIONS

Organisation of the competition

- 3.2.145** This event shall be organised in two series:
- 1) The qualifying heats to select the 4 best teams on the basis of their times;
 - 2) The finals.

The teams having made the two best times shall ride off the final for first and second places, the two others shall ride off the final for third and fourth places.

(text modified on 1.01.02).

- 3.2.146** [abrogated on 26.08.04].

- 3.2.147** In case of a draw, the best time made during the last lap shall decide.

- 3.2.148** If a team declares forfeit in a final, it shall not be replaced. The other team shall be declared the winner.

If the reason for which that team did not ride is not accepted, the absent team shall be disqualified.

(text modified on 1.01.02).

- 3.2.149** Teams shall be made up of riders entered for this event. The composition of a team may be modified from one heat to another. An incomplete team may not take the start.

The team manager must notify the commissaires of any changes prior of the relevant race.

(text modified on 1.01.02).

Race procedure

- 3.2.150** The start shall be taken in the middle of each straight. During the qualifying races, the place of each team shall be determined by the commissaires. Subsequently, the team having made the best time in the preceding stage of the competition, shall start in front of the main grandstand.

Race procedure

- 3.2.151** **The riders of each team shall start either side by side or staggered at an angle of 45° behind the start line. The distance between riders shall be one metre.**
(N) The rider, placed on the inside of the track, shall be held by a starting block and shall be the leading rider.

(text modified on 1.01.02; 26.08.04).

- 3.2.152** The leading rider shall lead the first lap and move towards the outside of the track and then drop back to leave the track without hindering the other team.

UCI CYCLING REGULATIONS

The rider that was in second position shall lead the following lap and then he shall drop out in the same manner.

The third rider shall end the last lap alone.

3.2.153 A team shall be relegated to the last place in the stage of the competition if one of the following infringements has been committed:

- 1) if a rider draws away by more than 15 metres before the end of the lap that he is to lead
- 2) if a rider does not draw away by more than 15 metres after the end of the lap that he was supposed to lead
- 3) if one rider pushes another.

(text modified on 1.01.02).

3.2.154 Qualifying rounds:

In the event of a mishap, the team must restart at the end of the qualifying rounds. Any team which may have been hindered by a mishap to its opponents may, by decision of the commissaires' panel, be granted a restart at the end of the qualifying rounds.

In the qualifying rounds a team may only be permitted two starts

(text modified on 1.01.02).

3.2.155 Finals:

In the event of a mishap the race shall be stopped and restarted. If the team suffers a further mishap (whether or not recognized) during its subsequent ride, it shall be relegated.

In each round, including the final, only one new start per team shall be permitted as a result of mishaps.

(text modified on 1.01.02; 26.08.04).

§ 10 Madison

Definition

3.2.156 The Madison Race is a race run over with intermediate sprints involving teams of 2 riders.

The ranking is determined on distance plus accrued points.

(text modified on 1.01.02).

UCI CYCLING REGULATIONS

Organisation of the competition

- 3.2.157** The race shall be conducted with a maximum of 18 teams on a track of less than 333.33 m and maximum 20 teams on a track of 333.33 m or more.

(text modified on 1.01.02).

- 3.2.158** The two riders of each team shall carry the same rider number but of different colours.

- 3.2.159** *At World Championships, each National Federation may enter just one team.*

- 3.2.160** *At World Championships, intermediate sprints shall be run every 20 laps, whatever the track length can be, for a total distance equal or close to 50 km for Elite Men and 30 km for Junior Men, according to the following table.*

Track length in metres	Number of laps		Number of sprints		Total distance in kilometres	
	Elite Men	Junior Men	Elite Men	Junior Men	Elite Men	Junior Men
250	200	120	10	6	50	30
285,714	180	100	9	5	51.4	28.57
333,33	160	100	8	5	53.3	33.33
400	120	80	6	4	48	32

(text modified on 1.01.02).

- 3.2.161** The first team in each intermediate sprint shall be awarded 5 points, the second 3 points, the third 2 points and the fourth one point.

(text modified on 1.01.02).

- 3.2.162** The placing shall be determined by distance according to the number of complete laps covered by each team. Teams having covered the same number of laps are placed according to the number of points scored. Where there is a draw on laps and points, **the places in the final sprint shall decide.**

(text modified on 1.01.02; 26.08.04).

Race procedure

- 3.2.163** One rider from each team shall make a standing start and ride until the first relay.

(text modified on 1.01.02).

- 3.2.164** Riders of a same team may relay one another at will by a touch of the hand or the shorts.

- 3.2.165** Sprints shall be run according to the Regulations governing Sprint.

UCI CYCLING REGULATIONS

3.2.166 A team shall be considered to have gained a lap when it catches up with the last rider of the largest bunch. A rider who drops behind the bunch shall not assist chasing rider(s) to gain a lap on the pain of disqualification of his team.

(text modified on 1.01.02).

3.2.167 If at the moment of a sprint considered for classification, one or some rider(s) catch up with the biggest bunch, this (these) rider(s) shall gain a lap. The points shall be given immediately to the riders of the break behind or to those ahead of the bunch.

(text modified on 1.01.02).

3.2.168 Teams lapped three times by the main bunch may be removed by the commissaires.

(text modified on 1.01.02).

3.2.169 Should one of the riders suffer a fall or mechanical incident, his team-mate shall immediately take the team position in the race. There shall be no neutralisation.

3.2.170 Should both team-mates fall simultaneously, the team shall be entitled to a neutralisation equal to the number of laps closest to 2,000 m. On returning to the track, one of the two team-mates shall resume the position that the team occupied in the bunch before the mishap.

There shall be no neutralisation in the last 2,000 m of the race. The team shall be placed according to the laps won or lost and the points won up to the moment of the mishap.

(text modified on 1.01.02).

3.2.171 In the case of a fall involving over one-half of the teams (calculated on the basis of one rider per team), the race shall be stopped and the commissaires shall determine the duration of the interruption. A new start shall be taken and each team shall retain the laps won or lost at the moment of the fall.

3.2.172 If the race is called of because of inclement weather, the commissaires shall decide as follows:

	Elite	Junior	
Race stopped before:	20 km	10 km	resume entirely the same day
Race stopped between:	20 and 40 km	10-25 km	resume race with points and laps acquired so far
Race stopped after:	40 km	25 km	let the result stand

(text modified on 1.01.03).

UCI CYCLING REGULATIONS

§ 11 Scratch

Definition

3.2.173 The Scratch Race is an individual race over a specified distance.

(text modified on 1.01.02).

Organisation of the competition

3.2.174 The races shall be held over the following distances:

Junior Women 7.5 km

Junior Men 10 km

Elite women 10 km

Elite Men 15 km

(text modified on 1.01.02).

3.2.175 In order to reach the maximum riders allowed on the track, qualifying heats shall take place to reduce the number of riders entered according to the chart below:

CATEGORY	DISTANCE TO RUN
Men	10 km
Women	7.5 km
Men Junior	7.5 km
Women Junior	5 km

(text modified on 1.01.02; 1.01.03).

Race procedure

3.2.176 Before the start, half of the riders shall be lined up along the railings, the other half lining up in single file in the sprinter's lane.

A flying start shall be taken after one neutralised lap.

(text modified on 1.01.02).

3.2.177 Riders overtaken by the main bunch shall immediately leave the track.

3.2.178 The final placings are determined during the final sprint, taking into account laps gained.

(text modified on 1.01.02; 1.01.03).

3.2.179 [abrogated on 1st January 2002].

UCI CYCLING REGULATIONS

3.2.180 In the case of collusion between riders, the commissaires may disqualify the riders concerned.

(text modified on 1.01.02).

3.2.181 The last lap of the race shall be indicated by a bell.

Mishaps

3.2.182 Riders suffering a **recognised** mishap shall be entitled to a neutralisation of:

- 3 laps on tracks of 400 metres or more
- 4 laps on tracks of 333.33 metres
- 5 laps on tracks of less of 333.33 metres.

No neutralisation will be granted in the last kilometre and any rider not ending the race will not be placed.

(text modified on 1.01.02; 26.08.04).

3.2.183 The race may be stopped in the case of a mass fall. The commissaires shall decide whether a fresh start shall be given for the complete distance or for the part of the distance remaining to be ridden from the positions at the moment of the fall.

The same rules shall apply where the race has to be abandoned because of inclement weather.

§ 12 Tandem

Definition

3.2.184 The «tandem» speciality shall be a «sprint» competition for tandems. It shall be run according to the rules applicable to the «sprint» speciality, except as stipulated below.

Organisation of the competition

3.2.185 Each pair of riders shall be considered a single participant.

3.2.186 The races shall be run as shown in the table in Article 3.2.050 according to the number of participants and by calculating from the final.

Nevertheless on tracks of 333.33 metres or less, a heat shall be ridden with a maximum of three tandems.

3.2.187 The qualifying heat shall be run over one lap with a flying start.

3.2.188 The race shall be run over the following distances:

- on tracks of less of 333.33 metres: 6 laps
- on tracks of 333.33 metres: 5 laps
- on tracks of more 333.33 metres: 4 laps
- on tracks of more of 450 metres: 3 laps

UCI CYCLING REGULATIONS

§ 13 Motor-Pacing

Definition

3.2.189 Motor-Pacing is a race in which each rider rides behind a motorcycle-mounted pacer.

Motorcycles and pacers

3.2.190 The Federation of the organiser shall provide ten motorbikes (of which two in reserve) complying with the description given in articles 3.6.007 to 3.6.028. The reserve motorcycles shall be used by any pacer or pacers whose motorcycle breaks down.

3.2.191 The commissaires shall check the motorcycles, if necessary with the help of a technician experienced in this type of work.

3.2.192 The check shall take place at the time indicated by the Commissaires Panel before each race.

3.2.193 After having been checked, the motorcycles shall be deposited in a locked enclosure, the keys of which shall be held by one of the commissaires. The motorcycles shall not be entrusted to the pacers until they are about to go on track.

3.2.194 Between two such checks, each pacer shall always use the same motorcycle.

3.2.195 Pacers shall hold a licence.

3.2.196 The Chief Commissaire shall designate two reserve pacers. These pacers, throughout the races, shall stand by ready to start up the reserve motorbikes if one of the machines in the race should break down.

Organisation of the competition

3.2.197 Pacing races may be held either over a set time (1 hour) or a set distance.

In the latter case, the distances shall be:

- heats: 25 km
- final: 2 legs of 30 km each

3.2.198 All the heats shall be run the same day.

3.2.199 The commissaires shall make up a number of heats according to the number of riders entered for the speciality.

There shall be at least two heats and each heat shall involve a maximum of 8 riders.

If there are two heats, the first three of each heat plus the fourth of the faster heat shall qualify for the final.

If there are three heats, the first two of each heat plus the third of the fastest heat shall qualify for the final.

UCI CYCLING REGULATIONS

If there are four or more heats, the winner of each heat plus the second of the fastest heats shall qualify in such a way that there be seven riders in the final.

3.2.200 The final shall be run in two legs at 30-minute intervals.

3.2.201 The following points scale shall be applied to each leg:

1st	50 points
2nd	35 points
3rd	25 points
4th	17 points
5th	11 points
6th	7 points
7th	4 points.

3.2.202 The final placings are obtained by adding the points won by each rider in the two legs. In the case of a draw, the place in the faster leg shall decide.

Race procedure

3.2.203 A demarcation line, known as the "stayers' line" shall be traced at a one-third of the total width of the track, but at a minimum of 2.50 m from of the outer edge.

The remaining part left free shall be wide enough to allow three riders to ride abreast.

3.2.204 Riding outside the demarcation line shall be forbidden. Should a participant do so, his opponents may not pass him on the inside or they will be disqualified.

3.2.205 A challenging rider may ride beyond the demarcation line only to come up on the right of the rider he is challenging, but at all times leaving a maximum of space to allow other riders to challenge also from the right.

3.2.206 The position of riders at the start of each heat and the allocation of motorcycles shall be determined by the drawing of lots on the track itself.

The starting position for the first heat of the final shall also be determined by drawing lots on the track itself. The position at the start of the second heat shall be the reverse of that in the first heat.

3.2.207 Each rider shall have the same pacer throughout the entire competition.

3.2.208 The pacers shall enter the track without the riders. On a signal from the starter, the pacers, after a few laps to warm up, shall take up their positions at the start.

3.2.209 The riders shall be lined up at the start in a set order.

3.2.210 The start of the race shall be given by a pistol shot. After one lap, the riders shall have fallen in behind their pacers.

UCI CYCLING REGULATIONS

- 3.2.211** A bell shall indicate the last lap of the leading rider. The placing shall be determined by the order in which the riders cross the finishing line and by the number of laps covered, it being understood that, once the winner has crossed the finishing line, the other riders shall cross it once only.
- 3.2.212** In time races, the bell shall be rung a minute before the hour. At the precise moment when the time expires, the timekeeper shall fire a pistol shot and the finishing judge shall draw up the placings on the first crossing of the line according to the distance covered by each competitor.
- 3.2.213** Once a rider has dropped a lap behind the leading rider, he may no longer stop, on pain of being eliminated from the race after a single warning.
- 3.2.214** Any rider falling more than 5 laps behind the leading rider shall be eliminated.

3.2.215 Pacers committing the following faults shall be punished as follows:

Penalty	Flag	Degree
warning	green	A
fine of 500 FS	green and yellow	B
fine of 750 FS and 15 days' suspension	yellow	C
fine of 1000 FS and 1 to 3 months' suspension	red	D

Infringement:

	1st	2nd	3rd	4th
1) Riding above the stayers' line with an opponent at less than 10 meters	A	B	C	D
2) Riding above the stayers' line when being challenged	B	C	D	
3) Riding above the stayers' line with an opponent along side	B	C	D	
4) Infringement (1), committed by a rider being overtaken	B	C	D	
5) Infringements (2) or (3), committed by a rider being overtaken	C	D		
6) Crowding to the railing while being challenged by an opponent	B	C	D	
7) Crowding to the railing while being challenged by two opponents	C	D		
8) Dropping back down with less than a 5 meter lead (cutting in)	C	D		
9) Attempt to pass four abreast	D			
10) Overtaking on the inside	D			
11) Riding with only one hand on the handlebar	A	B	C	D

3.2.216 In the case of a motorcycle breakdown or recognised mishap before the riders join their pacers, a false start shall be indicated and the race shall be restarted.

Should the same thing happen after the riders have joined their pacers, a neutralisation shall be granted for the number of laps closest to 1,500 metres, save during the last 5 laps or the last minutes of time races, in which case the race shall continue. The rider having suffered the mishap shall be placed in the position he held at the time of the mishap, if the commissaires consider that his result was a foregone conclusion. If that is not the case, he shall be placed last.

UCI CYCLING REGULATIONS

- 3.2.217** If the track becomes impracticable, the race shall be entirely restarted except if it is stopped during the last ten laps or, the two last minute in time races. In that case, the riders shall be placed according to their positions when they last crossed the finishing line.

§ 14 Elimination Race

Definition

- 3.2.218** The Elimination Race is an individual race in which the last rider in each intermediate sprint is eliminated.

Organisation of the competition

- 3.2.219** The organisation of the competition shall be governed by the specific race regulations.

Race procedure

- 3.2.220** Riders shall assemble on the finishing straight.
- 3.2.221** A flying start shall be taken after a neutralised lap during which the riders shall ride in a compact group at a moderate speed.
- 3.2.222** A sprint shall be run every second lap on tracks of less than 333.33 metres and every lap on tracks of 333.33 metres or more.
- On tracks of less than 333.33 metres, each lap that precedes the sprint shall be indicated by a bell.
- 3.2.223** After each sprint the last rider, according to the position of his rear wheel on the finishing line, shall be eliminated. He shall immediately leave the track.
- 3.2.224** The last two riders remaining in the race shall ride the final sprint. Their placing shall be based on the position of their front wheels on the finishing line.
- 3.2.225** The fact that a rider may gain a lap shall not count.
- 3.2.226** Riders suffering mishaps shall be eliminated. In the case of an mishap involving one or more riders, the next sprint shall be postponed by 1 or 2 laps according to the length of the track.
- When less than 8 riders remain in the race, a rider suffering an mishap shall be placed last in his group, even if he does not cover the distance.

§ 15 Six-Day Races

- 3.2.227** A "Six-Day Race" shall last six consecutive days with at least 24 hours' racing time.

UCI CYCLING REGULATIONS

3.2.228 The organiser shall be free to set the duration and the programme of the "Six-Day Race" within the limits set in article 3.2.227.

3.2.229 The "Six-Day Race" is a team race, each team comprising 2 or 3 riders who shall all wear jerseys bearing identical riders' number as indicated in article 1.3.044.

3.2.230 A "Six-Day Race" shall be run on a track of minimum length 140 m.

3.2.231 The organiser shall determine the number of teams according to the track length.

3.2.232 At the start of Madisons/chases (handicap races excepted), the illuminated indicator panel shall be set to zero (0) for all teams.

After the end of the Madisons/chases, the illuminated indicator panel shall again show the actual general placings for the race.

On the last day of race, when the final Madisons/chases is being run, the illuminated indicator panel shall indicate the actual general placings at all times.

(text modified on 1.01.04).

3.2.233 [abrogated on 1st January 2004].

3.2.234 Should a mechanical mishap occur and be recognised as valid by the commissaires, or should a rider fall, the team shall be entitled to a 1.5 km neutralisation (number of laps closest to 1.5 km). In the case of an mishap not recognized by commissaires or on expiry of the neutralisation, one of the team members shall resume the race 100% from the position occupied at the moment of the mishap, failing which the team shall be penalised by the number of laps lost.

(text modified on 1.01.04).

3.2.235 Laps gained by a team, one of whose members has been neutralised, shall be recognised only if the rider who remained in the race covers the full distance, i.e. does not miss a single relay.

3.2.236 During a timed Madison/chase, a team reduced to a single rider shall leave the track 10 laps before the end of the Madison/chase.

(text modified on 1.01.04).

3.2.237 The Track Manager, with the agreement of the Commissaires Panel, shall be entitled to create a temporary team comprising riders whose team-mates have been neutralised. Such riders shall wear identical jerseys and numbers. To determine the provisional position of such a provisional team, the number of laps covered by each of the original teams from which the members of the provisional team were drawn shall be added, rounded down to the nearest even number and divided by two.

UCI CYCLING REGULATIONS

When the provisional team is finally disbanded, laps gained or lost and any points won shall be credited towards the general placings of the original teams from which each of the members of the provisional team were drawn.

- 3.2.238** If a rider is neutralised, his team mate shall continue the ongoing chase according to the articles 3.2.235 and 3.2.236. If the neutralised rider is unable to continue the following chase, all the team shall be neutralised.

After the chase, the neutralised team shall be placed in the same position as the closest team in the general classification at the beginning of the race, including the laps lost by this team during the chase. The gained laps shall not be considered.

Moreover, the neutralised team shall be penalised by one lap.

- 3.2.239** The race doctor may decide to neutralise a rider for a maximum period lasting until 36 hours, after which the rider shall be eliminated.

(text modified on 1.01.04).

- 3.2.240** Should a rider abandon the race, the team shall be disbanded. The remaining rider shall participate in all the individual events.

If he has not been included in another team within 48 hours, he shall be eliminated.

- 3.2.241** Should a new team be created, account shall be taken of the placing of the best team disbanded plus one lap's penalty.
The points won by the two teams will be added and divided by two.

- 3.2.242** Points shall be awarded as follows:
- Sprint: 5, 3, 2, 1 points; points doubled during the final hour of the "Six-Day" event
 - Madison, 45 min of race and more: 25, 15, 10, 6, 4, 2 points
 - Madison less than 45 min of race: 15, 10, 8, 6, 4, 2 points
 - All other specialities (except behind Dernys): 15, 10, 8, 6, 4, 2 points
 - Races behind Dernys.

- 3.2.243** As it is impossible to run all teams on track together for the same race, the event has to be run in heats. The following procedure shall then apply:

- A. 1 heat with teams from the 1st half of the general classification: with 1 rider or per team: 10-8-6-4-2 points.
- per team (one relay in mid-race): 10, 8, 6, 4, 2 points
 - Madison: 15, 10, 8, 6, 4, 2 points
- 1 heat with teams from the 2nd half of the general classification: with 1 rider or per team: 10-8-6-4-2 points.
- per team (one relay in mid-race): 10, 8, 6, 4, 2 points
 - Madison: 15, 10, 8, 6, 4, 2 points.

UCI CYCLING REGULATIONS

- B. 2 heats with teams from the 1st half of the general classification: with 1 rider: 5-4-3-2-1 points.
2 heats with teams from the 2nd half of the general classification: with 1 rider: 5-4-3-2-1 points.

Laps won in races behind dernys do not count for the overall ranking.

(text modified on 1.01.04).

- 3.2.244** Apart from the final Madison/chase of the «Six-Day Race», teams shall be credited with one bonus lap for every 100 points logged.
Bonus laps can also be given in special events like time-trials, but only if all teams are allowed to participate in the event.

(text modified on 1.01.04).

- 3.2.245** All points won in the individual and team events shall count towards the general placings.

All laps won in races in which there is at least one rider of each team on track shall count towards general classification.

- 3.2.246** Each day, in addition to the partial classification of the race or stage, a general classification shall also be prepared on the basis of the number of laps completed and points acquired.

The total distance covered over the six racing days, expressed in complete laps, and the total number of points obtained shall determine the final classification.

The points classification shall be used to classify teams with the same number of laps. The team with the greatest number of laps, regardless of the score obtained, shall be declared the winner.

To distinguish team with equal laps and equal points, account shall be taken of the finishing order of the teams in the final sprint.



Chapter UCI INDIVIDUAL TRACK CLASSIFICATION

[chapter introduced on 31.05.04].

- 3.3.001** The UCI has created an annual individual classification system for riders participating in the races referred to in article 3.3.009.

This classification shall be called the «UCI Track Individual Classification» and shall be the exclusive property of the UCI.

- 3.3.002** A classification shall also exist of the corresponding nations and shall be the exclusive property of the UCI.

UCI CYCLING REGULATIONS

3.3.003 The classification shall be established according to the points obtained by riders participating in Track races on the International calendar, divided into classes according to article 3.8.003.

The classification starts from scratch 4 weeks after the Elite World Championships and ends at the end of the following edition of the Elite World Championships. During the break between two classification period no points will be awarded.

The track commission may grant dispensation in case of unpredictable late change of the Elite World Championships dates.

3.3.004 The number of points to be won in each race is indicated in article 3.3.010.

For the competitions in classes 1 to 4, only events matching the participation criterias will award UCI points.

3.3.005 For each event UCI points will be awarded once per event in each competition.

For the competitions run as a tournament, UCI points will be awarded according to the overall standings of the speciality. In the absence of overall standings, the event which will award the UCI points shall be clearly identified on the programme of the competition, failing that, the points will not be awarded.

3.3.006 National Federations and organisers shall be required, immediately following the end of the race, to transmit to UCI Headquarters by e-mail or telefax the list of starters and complete results. For races over several days, this information shall be transmitted within 72 hours of the end of the last day race.

All National Federations shall immediately communicate any facts or decisions that could result in an amendment to the points obtained by a rider.

Should such information not be transmitted, the Management Committee may declassify the race in question or exclude it from the Calendar, notwithstanding any other penalties provided for in the Regulations.

3.3.007 The Individual Classification and the Classification by Nation shall be drawn up at least twice a month.

If need be, the classification of preceding months will be corrected.

3.3.008 The UCI Management Committee may award prizes to riders, in accordance with such criteria as it may establish and with their placing within the system of Classification.

Should the Classification be rectified, prizes already awarded shall be returned and given to the entitled riders according to the revised Classification.

UCI CYCLING REGULATIONS

Classification of events

- 3.3.009** Olympic Games
World Championships
World Cup
Regional Games
Continental Championships
International events
Classes 1, 2, 3, 4

Individual Classification

- 3.3.010** Points are awarded according to the following scale:

UCI CYCLING REGULATIONS

Rank	ELITE / U23 / JUNIOR				ELITE / U23 / JUNIOR				Rank					
	World Championships*		World Cups*		Continental Championships		Regional Games							
	M	W	M	W	M	W	M	W						
	Individual events													
1	400	400	240	240	160	160	100	100	40	40	10	10	1	
2	240	240	200	200	120	120	75	75	35	35	24	24	2	
3	200	200	160	160	100	100	60	60	30	30	20	20	3	
4	180	180	130	130	80	80	35	35	25	25	18	18	4	
5	160	160	110	110	60	60	25	25	20	20	16	16	5	
6	140	140	90	90	40	40	20	20	18	18	14	14	6	
7	120	120	70	70	20	20	18	18	16	16	12	12	7	
8	100	100	60	60	10	10	16	16	14	14	10	10	8	
	Madison													
1	400 (2 x 200)	—	240 (2 x 120)	—	160 (2 x 80)	—	100 (2 x 50)	—	70 (2 x 35)	—	40 (2 x 20)	—	12 (2 x 6)	—
2	240 (2 x 120)	—	200 (2 x 100)	—	120 (2 x 60)	—	60 (2 x 30)	—	36 (2 x 18)	—	24 (2 x 12)	—	10 (2 x 5)	—
3	200 (2 x 100)	—	180 (2 x 90)	—	100 (2 x 50)	—	48 (2 x 24)	—	30 (2 x 15)	—	20 (2 x 10)	—	8 (2 x 4)	—
4	180 (2 x 90)	—	160 (2 x 80)	—	80 (2 x 40)	—	38 (2 x 19)	—	24 (2 x 12)	—	18 (2 x 9)	—	6 (2 x 3)	—
5	160 (2 x 80)	—	140 (2 x 70)	—	60 (2 x 30)	—	30 (2 x 15)	—	20 (2 x 10)	—	16 (2 x 8)	—	5 (2 x 2.5)	—
6	140 (2 x 70)	—	120 (2 x 60)	—	40 (2 x 20)	—	24 (2 x 12)	—	16 (2 x 8)	—	14 (2 x 7)	—	4 (2 x 2)	—
7	120 (2 x 60)	—	100 (2 x 50)	—	20 (2 x 10)	—	20 (2 x 10)	—	14 (2 x 7)	—	12 (2 x 6)	—	3 (2 x 1.5)	—
8	100 (2 x 50)	—	80 (2 x 40)	—	10 (2 x 5)	—	16 (2 x 8)	—	12 (2 x 6)	—	10 (2 x 5)	—	2 (2 x 0.5)	—
	Team Pursuit													
1	480 (4 x 120)	—	320 (4 x 80)	—	160 (4 x 40)	—	120 (4 x 30)	—	84 (4 x 21)	—	48 (4 x 12)	—	20 (4 x 5)	—
2	360 (4 x 90)	—	180 (4 x 45)	—	120 (4 x 30)	—	90 (4 x 22.5)	—	68 (4 x 17)	—	36 (4 x 9)	—	16 (4 x 4)	—
3	240 (4 x 60)	—	140 (4 x 35)	—	100 (4 x 25)	—	60 (4 x 15)	—	52 (4 x 13)	—	24 (4 x 6)	—	12 (4 x 3)	—
4	200 (4 x 50)	—	100 (4 x 25)	—	80 (4 x 20)	—	44 (4 x 11)	—	40 (4 x 10)	—	20 (4 x 5)	—	10 (4 x 2.5)	—
5	160 (4 x 40)	—	80 (4 x 20)	—	60 (4 x 15)	—	36 (4 x 9)	—	28 (4 x 7)	—	16 (4 x 4)	—	8 (4 x 2)	—
6	120 (4 x 30)	—	60 (4 x 15)	—	40 (4 x 10)	—	28 (4 x 7)	—	20 (4 x 5)	—	12 (4 x 3)	—	6 (4 x 1.5)	—
7	80 (4 x 20)	—	40 (4 x 10)	—	20 (4 x 5)	—	24 (4 x 6)	—	16 (4 x 4)	—	8 (4 x 2)	—	4 (4 x 1)	—
8	40 (4 x 10)	—	20 (4 x 5)	—	10 (4 x 2.5)	—	20 (4 x 5)	—	12 (4 x 3)	—	4 (4 x 1)	—	2 (4 x 0.5)	—
	Team Sprint													
1	360 (3 x 120)	—	270 (3 x 90)	—	180 (3 x 60)	—	90 (3 x 30)	—	60 (3 x 20)	—	36 (3 x 12)	—	15 (3 x 5)	—
2	240 (3 x 80)	—	210 (3 x 70)	—	150 (3 x 50)	—	60 (3 x 20)	—	48 (3 x 16)	—	24 (3 x 8)	—	12 (3 x 4)	—
3	180 (3 x 60)	—	150 (3 x 50)	—	120 (3 x 40)	—	45 (3 x 15)	—	39 (3 x 13)	—	18 (3 x 6)	—	9 (3 x 3)	—
4	150 (3 x 50)	—	120 (3 x 40)	—	90 (3 x 30)	—	36 (3 x 12)	—	30 (3 x 10)	—	15 (3 x 5)	—	7.5 (3 x 2.5)	—
5	120 (3 x 40)	—	90 (3 x 30)	—	60 (3 x 20)	—	27 (3 x 9)	—	24 (3 x 8)	—	12 (3 x 4)	—	6 (3 x 2)	—
6	90 (3 x 30)	—	60 (3 x 20)	—	30 (3 x 10)	—	24 (3 x 8)	—	18 (3 x 6)	—	9 (3 x 3)	—	4.5 (3 x 1.5)	—
7	60 (3 x 20)	—	30 (3 x 10)	—	15 (3 x 5)	—	21 (3 x 7)	—	15 (3 x 5)	—	6 (3 x 2)	—	3 (3 x 1)	—
8	30 (3 x 10)	—	15 (3 x 5)	—	6 (3 x 2)	—	18 (3 x 6)	—	12 (3 x 4)	—	3 (3 x 1)	—	1.5 (3 x 0.5)	—

* Elite only, M = Men, W = Women

UCI CYCLING REGULATIONS

IV

Chapter UCI WORLD TRACK CUP

- 3.4.001** The International Cycling Union has created a "World Track Cup", comprising a general classification by nation based on a number of competitions designated each year by the UCI Management Committee.
- 3.4.002** The World Track Cup shall be the exclusive property of the UCI.
- 3.4.003** Specialities selected for the World Cup shall be the same for the World Championships:

MEN

- 1) 1 km TT, standing start
- 2) Sprint
- 3) Individual pursuit, 4 km
- 4) Team pursuit, 4 km
- 5) Keirin
- 6) Team sprint
- 7) Points race, 30 km
- 8) Madison, 40 km
- 9) Scratch race, 15 km

WOMEN

- 1) 500 m TT, standing start
- 2) Sprint
- 3) Individual pursuit, 3 km
- 4) Keirin
- 5) Points race, 20 km
- 6) Scratch race, 10 km

(text modified on 1.01.02; 1.01.03).

Participation

- 3.4.004** The competitions shall be for national selections comprising riders aged 18 and over.

The participation in each competition of the world cup determines the qualification numbers of the national federations to the world championships according to article 9.2.027bis.

(text modified on 1.01.03).

- 3.4.005** Enrolment shall be open to UCI-affiliated National Federations.
- 3.4.006** Each national team shall comprise a maximum of 14 riders with a maximum of 9 men and 5 women.

(text modified on 1.01.02).

UCI CYCLING REGULATIONS

3.4.007 The number of participants by nation for each race shall be the following:

MEN		WOMEN	
1 km Time Trial	1	500 m Time Trial	1
Sprint	2	Sprint	2
Keirin	1	Keirin	2
Team Sprint	3	Individual pursuit	1
Individual pursuit	1	Points race	2
Team pursuit	4	Scratch race	2
Points race	1		
Madison	2		
Scratch race	1		

(text modified on 1.01.02; 1.01.03; 26.08.04).

3.4.008 National Federations shall confirm their participation by means of an enrolment form within **6 weeks** before the date of the race.

That confirmation shall mention the number of persons making up each delegation.

(text modified on 26.08.04).

3.4.009 The names of riders, substitutes and attendants shall reach the organiser by **3 weeks** before the date of the race at the latest.

In case of the non-attendance of nominated athletes after confirmation, the following penalties may be imposed:

- A financial penalty equal to the travel costs of the athletes or minimum 2'000.- sfr. per athlete. This penalty shall be paid to the organization. The rider's National Federation shall be held jointly liable for paying the penalty.

(text modified on 26.08.04).

Organisation

3.4.010 Organisers of World Cup races shall sign a contract with the UCI governing, notably, the radio and TV broadcasting rights, marketing rights and the material organisation of the races.

3.4.011 The teams' expenses shall be met by the organiser from noon on the day preceding the competitions until the day following the competitions, making a total of 4 nights.

3.4.012 The organiser shall pay, in addition of the riders, for:
1 attendant for teams of fewer than 3 riders

- 2 attendants for teams of 3 to 5 riders;
- 3 attendants for teams of 6 to 10 riders;
- 4 attendants for teams of 11 to 14 riders.

UCI CYCLING REGULATIONS

He shall provide accommodation, breakfast and 2 hot meals a day served in accordance with the competitions' schedule.

Any teams wishing to stay longer shall do so at their own expense and shall inform the organiser to this effect.

(text modified on 1.01.03; 26.08.04).

- 3.4.013** The Commissaires Panel shall comprise 4 UCI international commissaires including the Chief Commissaire and the Secretary who shall be appointed by the UCI.

The organising National Federation shall designate the starter, the finishing judge and all other commissaires that may be necessary for the efficient control of the races, as well as timekeepers.

(text modified on 1.01.02).

- 3.4.014** The UCI shall appoint a Technical Delegate.

(text modified on 1.01.02).

- 3.4.015** The organiser shall meet the expenses of all persons designated by the UCI, but they will be paid by UCI according to usual conditions.

- 3.4.016** A meeting shall be convened at 6 pm on the eve of the first competition. It shall be attended by all the officials and the Team Leaders. It shall be chaired by the Chief Commissaire in the presence of the UCI Technical Delegate and the persons responsible for organisation.

Prizes

- 3.4.017** The scale of prizes for the individual classification by race will be established annually by the UCI Management Committee in the financial obligations.

(text modified on 1.01.02).

- 3.4.018** [abrogated on 1st January 2002].

- 3.4.019** The prizes shall be paid out by the organiser at the end of each competition to the representatives of the respective teams.

(text modified on 1.01.02).

- 3.4.020** The 3 first in each race shall receive from the organiser, respectively, a gold medal (1st place), a silver medal (2nd place) and a bronze medal (3rd place).

The nation obtaining the top classification in the competition shall also receive some work of art from the organiser.

UCI CYCLING REGULATIONS

Classification

3.4.021 On completion of each of the 15 races in each competition, the first ten riders shall be awarded the following number of points:

1st	12 points
2nd	10 points
3rd	8 points
4th	7 points
5th	6 points
6th	5 points
7th	4 points
8th	3 points
9th	2 points
10th	1 point

(text modified on 1.01.02).

3.4.021 bis At the end of each competition, the order of precedence between riders drawing in the general classifications shall be determined according to the greatest number of 1st places, then 2nd places, etc. considering only the placings for which points are awarded.

If they still stand equal, precedence shall be awarded to the rider with the best classification in the most recent event.

(article introduced on 1.10.04).

3.4.022 The general classification of the competition by nation shall be determined by adding the points obtained by the riders of each team in each of the 15 races.

In case of a tie on points, the number of first places shall be taken into account, then the number of second places, and so on.

(text modified on 1.01.02).

3.4.023 The total points obtained by each nation in each competition shall serve, after the last competition of the year, to establish the final general classification by nation.

3.4.024 The UCI shall award the UCI WORLD TRACK CUP trophy for the first nation in the final general classification.

(text modified on 1.01.02).

3.4.025 The UCI shall award a World Cup leader's jersey for the first rider in the final general classification of each event.

UCI CYCLING REGULATIONS

The World Cup leader shall wear his jersey in all track races, including the World Championships, in the category of which he is the leader and no other race.

(article introduced on 26.08.04; modified on 1.10.04).

V

Chapter WORLD RECORDS

General comments

3.5.001 The UCI shall recognise solely World Track Records in the following categories and specialities:

Flying start:
All categories: 200 m and 500 m.

Standing start:
Men: 1 km, 4 km, 4 km team, hour record, best hour performance
Women: 500 m, 3 km, hour record, best hour performance
Junior Men: 1 km, 3 km, 4 km team
Junior Women: 500 m, 2 km

(text modified on 1.01.02).

3.5.002 The World Record is the exclusive property of the UCI.

The UCI is the exclusive holder of all audio-visual, marketing and other rights relating to any attempt to set a world or any other record. The UCI may surrender those rights on any conditions that it may determine.

(text modified on 1.01.02).

3.5.003 Only the UCI may recognise and confirm a world record.

(text modified on 1.01.02).

3.5.004 The UCI also recognises and confirms Olympic records

3.5.005 Records may be set during a competition or during a special attempt that shall also be ridden in accordance with the relevant UCI regulations.

A special attempt must be authorized in writing in advance by the national federation of the rider(s). This authorization must reach the UCI no later than one month prior to the attempt.

UCI CYCLING REGULATIONS

Specific world record attempts shall not take place during the world championship competitions other than for the hour record or the best hour performance.

(text modified on 1.01.02).

3.5.006 The public and the Press shall be able to attend World Record attempts for their full duration.

The number of spectators and Press personnel may be limited in the interest of sporting performance, subject to prior UCI agreement.

3.5.007 For record attempts outside competition the rider or the team shall take the track alone.

(text modified on 1.01.02).

3.5.008 Records must be set on a UCI-approved track.

Only bicycles admitted by the Track Race Regulations may be used.

A starting block shall be used in all specialities with a standing start, including the hour record.

3.5.009 If the record attempt takes place in a country other than that of the National Federation of the rider, both Federations shall reach an agreement which shall ensure that the attempt may be made under the best possible circumstances, especially with regard to policing services, timekeeping, commissaires and the drug test.

(text modified on 1.01.02).

3.5.010 Any costs incurred by the attempt shall be met by the rider (including the travel and accommodation costs of the international commissaire and the drug-test inspector, the laboratory costs and other UCI expenses).

If the attempt takes place in some other country, the National Federation of that country shall be entitled to be reimbursed any expenses it may have had to incur.

The rider's National Federation shall be held jointly liable for paying costs incurred by the attempt.

Time-keeping

3.5.011 Record attempts shall be electronically timed lap by lap to the nearest thousandth of a second.

3.5.012 Electronic time-keeping of hour record attempts must be accompanied by a system of manual time-keeping. That time-keeping shall be conducted by two timekeepers approved by the National Federation of the country where the attempt takes place.

3.5.013 Recorded times shall be entered on the time-keeping sheets that then have to be signed by the timekeeper that fills them in.

UCI CYCLING REGULATIONS

Verification

3.5.014 A record set during a competition shall be confirmed only if a UCI international commissaire has been monitoring the race as member of the Commissaires Panel and signs the report referred to in article 3.5.016.

3.5.015 Any record attempt shall be authorised beforehand by the National Federation of the country where the attempt takes place. The National Federation shall appoint a UCI international commissaire to supervise the attempt. For an hour record attempt, the commissaire shall be appointed by the UCI.

Report

3.5.016 A succinct report specifying the circumstances in which the record has been set shall in all cases be drawn up on the models provide by the UCI. The report shall be immediately written and signed by the UCI international commissaire and by at least one other official present and by the rider(s) who set the record.

See appendix 1

(text modified on 1.01.02).

3.5.017 The international commissaire shall then send the report, with the original time-keeping sheets, to the UCI.

Drug Test

3.5.018 No World Record can be confirmed if the rider in question did not submit to the drug test conducted in accordance with the UCI Anti-doping Examination Regulations at the end of the race. For the four kilometre team speciality, all 4 riders shall take the test.

The record can be confirmed only on the basis of a certificate issued by the laboratory indicating that the test proved negative.

(text modified on 1.01.02).

Confirmation

3.5.019 No record shall be confirmed if it does not comply with all applicable provisions.

3.5.020 A record beaten the same day shall not be confirmed.

3.5.021 Records established during World Cup rounds, World Championships and Olympic Games may be confirmed by a certified copy of the official result communiqué, signed by the Chief Commissaire and by a member of the UCI Technical Commission. In case of disagreement, a request for conformation may be lodged with the Management Committee pursuant to the following articles.

(text modified on 1.01.02).

3.5.022 Notwithstanding the application of article 3.5.021, a World Record shall be recognised only if confirmed by the UCI.

UCI CYCLING REGULATIONS

3.5.023 A request for confirmation shall be lodged by the rider that set the record or by his National Federation. To be considered, the request shall have reached UCI headquarters at the latest one month after the date the record was set.

3.5.024 If the UCI considers that there exist circumstances opposing confirmation, it shall invite the rider or his representative to elucidate those circumstances before taking a decision. If that is not done and if the record is not confirmed, the rider may lodge an appeal with the Appeals Board.

3.5.025 The UCI shall keep an up-to-date list of confirmed world records which it shall publish regularly.

Hour Record

3.5.026 The Hour Record is the greatest distance achieved in one hour on a traditional bicycle, as defined in articles 1.3.006 to 1.3.010 and 1.3.019 of the rules, and as further defined in the following specifications:

- Triangular frame composed of straight, circular section tubes with a minimum diameter of 2.5 cm.
- Traditional style handlebars with an overall width of 50 cm maximum and 34 cm minimum.
- Two wheels of equal diameter, measuring 65 to 70 cm, including tyres.
- Tyre section of a minimum of 16 mm and a maximum of 25 mm.
- Spoked wheels with a minimum of 16 and a maximum of 32 spokes; the spokes may be round, flat or oval provided that none of their cross-sections exceeds 2 mm. (See diagram 1 below).
- Shallow, unelongated, non-profiled rims; shallow rims are understood to be rims whose cross-section fits inside a 2.2 cm square. (See diagram 2 below).
- Other measurements in accordance with those defined in articles 1.3.012 to 1.3.017 (see figure "Measurements") and 1.3.022, 1.3.024 and 1.3.025.

(1) The spokes may be round, flat or oval as long as the width of a cross-section at any point is no broader than 2 mm in any direction.

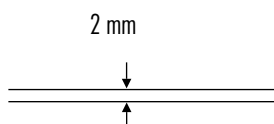

(2) Shallow rims are understood to be rims whose cross-section fits inside a 2.2 cm square.

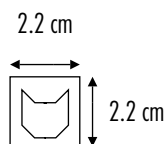

UCI CYCLING REGULATIONS

Riders must wear a helmet certified according to international safety standards, intended solely for the purposes of protecting the head, without a visor, and without any devices or shapes added to or moulded into the helmet with the intention of or having the effect of reducing air resistance.

Articles 1.3.026 and 1.3.033 will be strictly applied.

Best Hour Performance

3.5.027 The Best Hour Performance is the greatest distance achieved in one hour on a bicycle conforming to articles 1.3.006 to 1.3.010.

The bicycle shall be submitted to the Equipment Commission for approval 15 days before the date of the attempt.

3.5.028 The rider starts from the pursuit line as defined in article 3.6.083.

3.5.029 The timekeeper shall, by ringing a bell, indicate the last lap (or the lap during which the hour expires) when the time remaining to ride is less than the average time realised over one lap of the track.

3.5.030 The attempt shall terminate when the rider crosses the pursuit line from which he started. The end shall be indicated by a double pistol shot.

3.5.031 The distance covered in the hour shall be calculated as follows:

$$D = (L \text{ Pi} \times TC) + \text{Di C}$$

$$\text{Di C} = \frac{L \text{ Pi} \times \text{TRC}}{\text{TTC}}$$

Where: D = distance covered in the hour
 L Pi = length of track
 TC = number of complete laps before the last lap
 Di C = additional distance
 TTC = time of the last complete lap
 TRC = time remaining to ride at the beginning of the last lap

3.5.032 The distance covered shall be rounded down to the nearest metre. Neither the Hour Record nor the Best Hour Performance may be beaten by less than one metre.

3.5.033 If, between the expiry of the hour and the end of the last lap, an incident occurs to prevent completion of the lap, the additional distance shall be calculated on the basis of the time of the lap before last.

UCI CYCLING REGULATIONS

VI**Chapter EQUIPMENT AND INFRASTRUCTURE****§ 1 Starting Blocks**

3.6.001 The starting blocks shall be constructed in order that they are easy to handle and removable from the track surface in 5 seconds maximum. They must be tested and approved by the UCI Technical Delegate or the competition Chief Commissaire.

(text modified on 1.01.02).

3.6.002 The bicycle shall be held in a vertical position, whatever the banking of the track. For that purpose, the starting block shall be fitted with adjustable feet.

3.6.003 The bicycle shall be held firmly by means of a brake that grips the edge of the rear wheel rim.

(text modified on 1.01.02).

3.6.004 The brake shall be adjustable in height so that it can block wheels of different diameters and in width to grip rims of different thickness.

3.6.005 The brake shall release the rear wheel at the moment of the start, so that all competitors start at exactly the same moment.

3.6.006 (N) The brake of the starting block shall be released by the electronic system which simultaneously triggers the chronometer.

§ 2 Motorbikes for motor-pacing

3.6.007 Machines used for training shall comply with the drawing in article 3.6.028.

All the measurements in the drawing are taken from the centre of the rear wheel spindle or from a fixed point on the framework as near as possible to the rear wheel spindle (this point being clearly defined) and from the ground.

3.6.008 The machines shall be single track, of unspecified make and model and shall be driven by a single driver.

3.6.009 The engine and the frame shall correspond exactly to standards of the original model as defined by the constructor.

Engine

3.6.010 The engine capacity shall be 500 cc. minimum and 1000 cc. maximum.

UCI CYCLING REGULATIONS

3.6.011 These engines shall be of the single or double cylinder, vertical type. Flat Tween engines are forbidden.

Frame

3.6.012 The machine shall be of a commercially available type. The width of the framework shall be 350 mm. maximum. The rear shock absorber shall be removed and replaced by a round tube of the same diameter as the tubes of the frame, that is to say 30 mm.

Saddle

3.6.013 The saddle, of a commercially available type, shall be 300 mm wide and 350 mm long. The position of the pacer being what is referred to as "standing", the saddle shall be set tipped forward. The saddle may in no case be modified; the addition of cushions, leather, cloth, etc., which might afford additional shelter, shall be absolutely forbidden. The front outer edge of the saddle shall be set at 800 mm from the ground and 250 mm forwards of a perpendicular passing through the rear wheel spindle. The rearmost point of the saddle shall be set at 1030 mm from the ground and touching that same perpendicular passing through the rear wheel spindle.

Wheels

3.6.014 The wheels shall comprise metal rims and commercial spokes. They shall be of a maximum diameter of 650 mm. Tyres: front wheel 350 x 19, rear wheel 350 or 400 x 19.

3.6.015 A reliable brake shall act on the front wheel. The brake acting on the rear wheel shall serve merely to slow down the bicycle.

Handlebar

3.6.016 The handlebar shall be made in one piece. Its width to the rear shall be 700 mm maximum (width taken at the exterior of the grips).

3.6.017 The two grips shall be of the same height. The height above the ground shall be 1000 mm minimum and 1050 mm maximum. The height may be adjustable within those limits.

3.6.018 The rear extremity of the grips of the handlebar shall pass through the same perpendicular to the ground as that passing through the foremost point of the saddle, that is to say 250 mm forwards of the rear wheel spindle.

3.6.019 No lever or any other controlling device may, in its operating position, project beyond the rearmost extremity of the grips. Leather devices, levers or hooks and other accessories fixed to the grips shall be absolutely forbidden.

3.6.020 Each pacer shall hold his handlebar with both hands. Driving with one hand alone shall be authorised only when adjusting the engine or in cases of danger.

Footrests

3.6.021 Footrests shall be fixed to the frame tubes to the left and right. Each footrest shall comprise a "sole" and a sheet metal toe-cap.

UCI CYCLING REGULATIONS

- 3.6.022** The sole of the footrest shall comprise a flat plate, whose dimensions shall be 120 mm wide by 240 mm long overall. It shall be rounded into a semicircle to the rear. The toe-cap shall measure 80 mm to the fore and 200 mm to the rear; it shall be welded around the sole.
- 3.6.023** The centre of the footrest shall align on the same perpendicular to the ground as that of the foremost point of the saddle and rearmost points of the handlebar. The front of the footrests shall be permanently fixed at 240 mm from the ground.
- 3.6.024** The rear shall be adjustable. However, the both footrests shall always be set to the same height for all motorbikes used in any given competition.
- 3.6.025** The overall width between the outer edges of the two footrests shall be 650 mm maximum.

Roll

- 3.6.026** Each machine shall, behind the rear wheel, be fitted with a roll the tube of which shall be of a maximum diameter of 35 mm. The width of the roll shall be 600 mm. The centre of the roll spindle shall be set 335 mm from the ground.
- 3.6.027** The roll shall be fixed to the rear of the frame using cranked flat irons; the irons shall be 35 mm wide by 6 mm thick. Two distance pieces hold the roll in the correct position; these distance pieces shall also be made of flat iron strip, 35 mm wide by 6 mm thick. The distance between the rear-wheel spindle and the roll shall be adjustable in 50 mm steps from a minimum of 600 mm to a maximum of 800 mm.

3.6.028

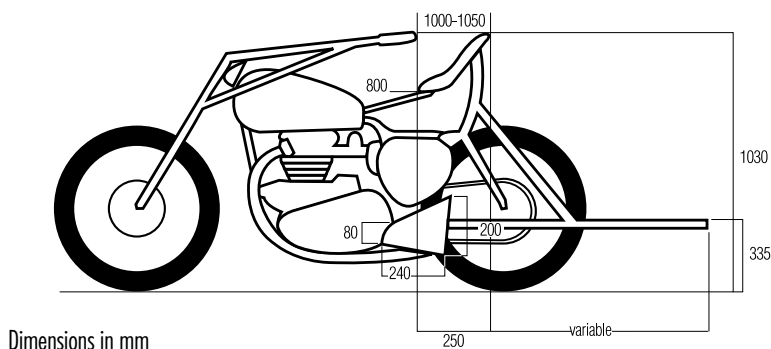

UCI CYCLING REGULATIONS

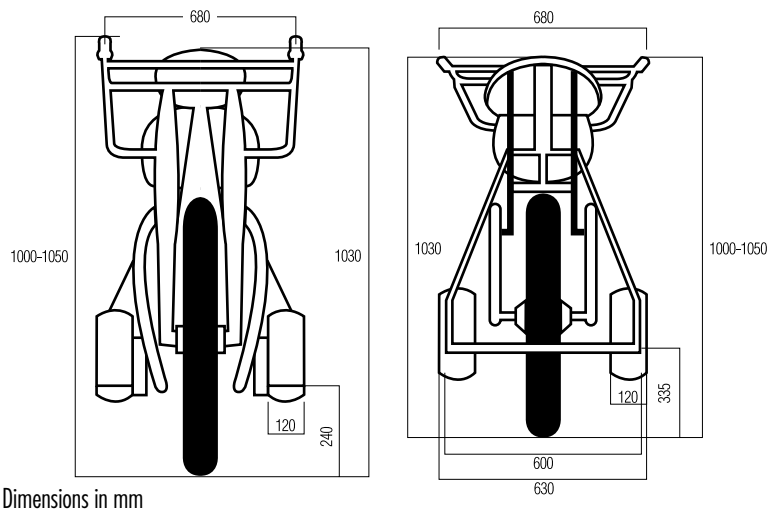

§ 3 Mopeds

- 3.6.029** As the moped is meant to replace human pacing, the shelter that it affords shall be fundamentally the same as that afforded by a bicycle.
- 3.6.030** No part of the moped may be surrounded by leather, rubber, felt or other materials that could act as an artificial wind-break.
- 3.6.031** The moped shall comply strictly with the following provisions.

Engine

- 3.6.032** The machine shall be fitted with an engine of 100 cc maximum which will serve merely to help the pacer pedal.
- 3.6.033** The use of a free wheel shall be absolutely forbidden; a fixed front chain-wheel shall be mandatory.

Frame

- 3.6.034** The machine shall be a single-track one-seater.
- 3.6.035** The machine, including the front fork, shall be made of tubing, similar in every respect to that used for the construction of an ordinary bicycle.
- 3.6.036** The height of the frame with a rake similar to that of a bicycle shall be between 560 mm minimum and 580 mm maximum (distance taken from the chainset spindle to the axis of the upper tube).

UCI CYCLING REGULATIONS

3.6.037 The height of the chainset spindle above the ground shall be from 230 mm minimum to 290 mm maximum.

3.6.038 The width of the chainset (including pedals) shall be 380 mm maximum.

Saddle

3.6.039 The saddle shall be of a commercially available racing model in leather; it shall measure 300 mm maximum in length by 150 to 180 mm in width. The saddle shall overhang the frame by an equal distance on each side.

3.6.040 The saddle may not be in any way modified. The addition of cushions, leather, cloth, etc. to provide additional shelter shall be absolutely forbidden.

3.6.041 The foremost tip of the saddle peak shall be placed:
(a) 450 mm from the axis of the steering expander tightening bolt on tracks of 200 metres and more;
(b) 400 mm from the axis of the steering expander tightening bolt on tracks of less than 200 metres.

3.6.042 The height of the rear of the saddle above the ground shall be 870 mm minimum.

Handlebar

3.6.043 The handlebar shall be made in one piece and be a maximum 500 mm across (distance measured at the extremities of the grips).

3.6.044 The handlebar shall be 30 mm below the level of the steering expander tightening bolt which bolt shall itself be 900 mm above the ground. The handlebar grips shall therefore be 870 mm from the ground (distance measured from the top of the grips).

For tracks of less than 200 m, the handlebar grips shall be 920 mm from the ground (distance measured from the top of the grips).

3.6.045 The rearmost points of the handlebar shall be 200 mm maximum to the rear of the steering expander tightening bolt. The tube ends shall be filled and the grips may be clad in insulating tape. Rubber grips shall be absolutely forbidden.

Wheels

3.6.046 The wheels shall comprise metal rims. They shall be of 650 mm diameter and fitted with a 55 mm section tyre.

3.6.047 The rear wheel shall be of 700 mm diameter and shall be fitted with a 42 mm section tyre.

Tank

3.6.048 The tank, being cylindrical, measuring 180 mm in diameter by 265 mm in length and taking a petrol (gasoline) and oil mixture, shall be fixed to the steering pin.

UCI CYCLING REGULATIONS

Mudguard

3.6.049 The mudguard shall be made of steel.

3.6.050 The width of the rear mudguard shall be 70 mm maximum. It shall be made as a single piece and form a protective shield on both sides. Its foremost point shall be fixed to the frame tubes and its rearmost point to the rear wheel spindle. It shall be 140 mm high. The distance between the steering expander button and the perpendicular with the ground passing through the rear end of the mudguard shall be 1250 mm. The distance between the rear of the saddle and the perpendicular with the ground, passing through the rear end of the mudguard, shall therefore be 500 mm minimum.

3.6.051

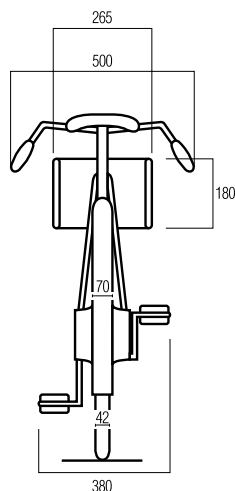

§ 4 Attire of motor-pacers

3.6.052 Motor-pacers shall wear a leather jacket of the following dimensions:

- length of the back without collar 67 cm
- width of the back at sleeve level 45 cm
- width of chest at sleeve level 35 cm
- circumference of chest taken under the arms 120 cm
- circumference of the bottom of the jacket 120 cm
- length of sleeve from shoulder seam to elbow 60 cm
- circumference of sleeve around biceps 40 cm
- circumference of sleeve around wrist 28 cm
- circumference of collar 44 cm
- height of collar 3.5 cm

3.6.053 The collar shall be closed by two hooks. The jacket shall zip up the back (from the bottom up).

3.6.054 The jacket may not be opened during the race or in any way modified for the purpose of favouring a rider.

UCI CYCLING REGULATIONS

3.6.055 Pacers shall wear leather trousers, without gaiters, and of the following dimensions:

- | | |
|--|--------|
| - length of outer leg | 94 cm |
| - length of inner leg | 68 cm |
| - circumference of waist | 102 cm |
| - circumference of hip across the buttocks | 114 cm |
| - circumference of thigh | 72 cm |
| - circumference above the knee | 48 cm |
| - circumference below the knee | 36 cm |
| - circumference of calf | 40 cm |
| - circumference of ankle | 30 cm |

3.6.056 The leather trousers shall also have a 22 cm wide cloth belt with, to the rear and pointing downward, a rubber tail 48 cm long by 9 cm wide.

3.6.057 The trousers shall have no openings other than on the outside of each leg, running 40 cm up from the ankle. These openings shall be secured by zip fasteners closing from the top down.

3.6.058 The trousers shall be held up by straps crossing and secured behind with rubberised loops.

3.6.059 Under their leather suits, pacers shall wear only a light, tight-fitting jersey and cyclist's racing shorts. The jacket must close without straining the seams or the zipper. The jerseys shall be of equal thickness throughout and may in no way be padded. There may be no openings in underclothes and jerseys.

3.6.060 Pacers may wear only one pair of socks. They must be held up by suspenders.

3.6.061 Only normal-size, fully enclosed leather boots shall be permitted.

3.6.062 A rigid helmet shall be worn at all times during racing and training. It may not be unstrapped or removed during the race. Ear-flaps, which may be fixed to the helmet, may not protrude by more than 1 cm by 3 cm.

§ 5 Attire of moped pacers

3.6.063 All pacers shall wear the same attire:

- a) a light, short-sleeved pullover
- b) a clinging rider's jersey with patch pockets; long sleeves shall be allowed; the commissaires may permit the wearing of a supplementary racing jersey
- c) shorts (tight black descending to mid-thigh)
- d) special black shoes known as "cyclists' shoes" and all-white or all-black socks
- e) a pair of racing gloves or a pair of normal unlined gloves but not gauntlet gloves
- f) a moulded shell hat of the type worn by stayers; it may have neither ear-flaps nor leather, felt or cloth strips that could act as artificial wind-breakers.

UCI CYCLING REGULATIONS

TECHNICAL SPECIFICATIONS AND VELODROMES HOMOLOGATION:

§ 6 Velodromes

3.6.064 Track events included on the UCI International calendar must be held at a UCI-homologated velodrome. Exceptionally, special dispensations may be granted by UCI for Velodromes in use prior to 2001.

Track events included on national calendar may be held at a nationally homologated or a UCI-homologated velodrome.

3.6.065 A velodrome may not be homologated by the UCI unless it meets the following conditions.

3.6.066 The stability and resistance of the materials and fixings which make up the structure of the velodrome shall meet the legislation regarding construction and safety of the country in which it is built and shall take account of specific geological and climatic conditions.

These elements, along with general compliance of the construction and construction materials with technical standards and good practice, remain the exclusive responsibility of the owner, contractor, architect, consulting engineer, proprietor, operator, user, organiser or others, in accordance with local legislation or regulations. The UCI is exempt from any responsibility in this regard.

Homologation of the velodrome by the UCI rests not on the technical and structural characteristics of the velodrome, but solely on the compliance of its external features with the provisions of the present paragraph at the time of the inspection. The UCI is not liable for any faults or defects which lie outside the scope of such homologation, or which appear or come to light subsequent to the inspections on which such homologation is based.

(text modified on 1.01.02).

TRACK GEOMETRY

Form

3.6.067 The inner edge of the track shall consist of two curves connected by two parallel straight lines. The entrance and exit of the bends shall be designed so that the transition is gradual.

The banking of the track shall be determined by taking into account the radius of the curves and the maximum speeds achieved in the various disciplines.

Length

3.6.068 The length of the track must lie between 133 metres and 500 metres inclusive.

UCI CYCLING REGULATIONS

The length of a track shall be such that a whole number of laps or half laps shall give a distance of precisely 1 kilometre, with a tolerance of + 5 centimetres.

For the World Championships and the Olympic Games the length must lie between 250 metres and 400 metres inclusive.

(text modified on 1.01.02).

3.6.069 The length of the track shall be measured 20 cm above the inner edge of the track (the upper edge of the blue band).

Width

3.6.070 The width of the track must be constant throughout its length. Tracks approved in categories 1 and 2 must have a minimum width of 7 metres. Others tracks must have a width proportional to its length of 5 metres minimum.

(text modified on 1.01.02).

Blue band

3.6.071 A rideable area sky-blue in colour known as the "blue band" must be provided along the inside edge of the track. The width of this band must be at least 10% of the width of the track and its surface must have the same properties as of the track. No advertising inscription is permissible in this area.

With the exception of mounted riders, no person or object may be on the blue band while one or more riders are on the track.

(text modified on 1.01.02).

Safety zone

3.6.072 Immediately inside the blue band there shall be a prepared and marked safety zone. The combined width of the blue band and the safety zone shall be at least 4 metres for tracks of 250 metres and over, and 2.5 metres for tracks shorter than 250 metres.

With the exception of the commissaires, mounted riders **or other persons authorised by the chief commissaire**, no person or object (including starting blocks) may be inside the safety zone when a rider is on the track.

(text modified on 1.01.02; 26.08.04).

3.6.072 bis A fence, of a construction ensuring the adequate safety for riders at a height of at least 120 cm, must be erected on the inner edge of the safety zone except if the following conditions are met:

- 1) there are no height difference or abrupt gradient between the safety zone and the track centre or within the track centre, and
- 2) inside the safety zone and at a distance of 10 m of the blue band, is no unauthorized person or object in accordance with article 3.6.072.

UCI CYCLING REGULATIONS

The fence must be transparent and in no circumstances may any advertising **boards** be attached to it.

In places where the level of the track proper is more than 1.5 m. higher than the actual track centre, additional protective measures such as nets, panels, or the like, shall be erected in order to prevent athletes being subjected to injury.

Any gates provided in the fencing must be fitted with simple and reliable fastenings. They must be kept closed while racing and training is in progress.

(text modified on 1.01.02; 26.08.04).

Profile

3.6.073 At any point on the track, a cross section of the track surface must present a straight line. In the bankings, the inner edge should have a curved transition onto the blue band.

3.6.073 bis At any point of the track or safety zone surface, a perpendicular distance from the surface of at least 3 metres must be guaranteed free of any obstacle.

(text modified on 1.01.02).

Surface

3.6.074 The surface of the track shall be completely flat, homogenous, non-abrasive. The tolerance of flatness for the track surface shall be 5 mm over 2 metres. The coating shall be uniform in all its aspects over the entire track surface. Coatings intended to improve the rolling qualities of one part of the track only are not permitted.

(text modified on 1.01.02).

3.6.075 The surface colour of the track must leave the track marking lines clearly visible.

MARKING

Painting

3.6.076 Any demarcation, line, advertisement or other marking on the track must be applied with a paint or product which is non-slip and which does not alter the adhesion properties, consistency or homogeneity of the surface.

(text modified on 1.01.02).

3.6.077 Advertisements on the track surface must be placed above the stayers' line within a longitudinal band between 50 cm of the stayers' line and 50 cm from the fence (the outside edge of the track). No advertisement may be placed within 1 m either side of the pursuit and the 200 m lines, or within 3 m either side of the finish line, measured from the outside edge of the white band.

(text modified on 1.01.02).

UCI CYCLING REGULATIONS

- 3.6.078** The longitudinal lines covered by articles 3.6.079 to 3.6.081 shall have a constant width of 5 cm. The perpendicular lines covered by articles 3.6.082 to 3.6.084 shall have a constant width of 4 cm.

Longitudinal markings:

Measuring line

- 3.6.079** A line, in black on a light background or in white on a dark background, known as the "measuring line" shall be drawn at 20 cm from the inside edge of the track, numbered every 10 metres and marked every five metres. The measurement of the measuring line shall be taken on its inside edge.

Sprinters' line

- 3.6.080** A red line, known as the "sprinters' line" shall be marked out 90 cm from the inner edge of the track.

The 90 cm distance is measured to the outside of this red line.

Stayers' line

- 3.6.081** A blue line, known as the "stayers' line" shall be drawn at one third of the total width of the track or 2.5 m (whichever is the greater) from the inner edge of the track.

The distance is to be measured to the outside of the blue line.

Perpendicular markings:

Finish line

- 3.6.082** The finish line shall be situated towards the end of one of the straights but at least a few metres before the entrance of the banking, and in principle in front of the main grandstand. It shall be marked by a perpendicular black line 4 cm in width at the centre of a white band 72 cm in width. The finish line marking on the track shall continue up to the top of the flat surface of the fencing.

200 metre line

- 3.6.083** A white line shall be drawn across the track 200 metres before the finish line, from which point the times will be taken for sprint events.

Pursuit lines

- 3.6.084** Two red lines half the width of the track in length, perpendicular to the track and precisely in line with one another, shall be drawn at the precise midpoint of each of the straights to mark the finish points for pursuit events.

UCI CYCLING REGULATIONS

EQUIPMENT

Access tunnel

- 3.6.085** The track centre, which is located inside the safety zone, must be obligatorily accessible via one or more tunnels.

Riders' area

- 3.6.086** Within the track centre areas must be provided for riders to change and warm up, as well as waiting areas near the pursuit and finish lines.

Fencing

- 3.6.087** The outside edge of the track must be surrounded by a safety fence to protect riders and spectators. It must be stable and solidly mounted, with an overall height of at least 90 cm. The inside part must be completely smooth and unbroken to a height of at least 65 cm above the track. It must present no protrusions or projecting parts.

At the places where the area outside the track is at a level 1.5 metres or more below the outside edge of the track surface, additional protective measures (nets, panels, etc.) must be provided to reduce the risks resulting from riders accidentally leaving the track.

The colour of the outside fencing must contrast clearly with that of the track.

Any gates provided in the outside fencing must open outwards and be fitted with simple and reliable fastenings. They must be kept closed while racing and training is in progress.

(text modified on 1.01.02).

Miscellaneous

- 3.6.088** A lap counter clearly visible to riders and spectators and a bell audible through-out the track area shall be placed near the finish line.

For pursuit events, bells and lap counters shall be placed on both side of the track, near the pursuit lines, in accordance with article 3.2.066.

(text modified on 1.01.02).

- 3.6.089** A timing system including starting blocks, contact bands and an electronic display (times to the thousandth of second, laps, points, etc.), a photofinish or video-finish system to assist in judging finishes, and a general public address system clearly audible throughout the entire velodrome area must be provided.

Contact strips must be laid over the width of the track or an acceptable timing detector such as light beams installed.

(text modified on 1.01.02).

UCI CYCLING REGULATIONS

Lighting

3.6.090 Suitable lighting must be provided which meets the safety conditions into force in that country.

The lighting system must be supplemented by an emergency lighting system operating independently of mains electricity, capable of providing an intensity of at least 100 Lux for 5 minutes which must be effective instantaneously.

During training sessions without spectators, vertical lighting must be at least 300 lux. During competitions at least 1400 Lux is required for the Elite World Championships and the Olympic Games (category 1 velodromes), at least 1000 Lux for category 2 velodromes and at least 500 Lux for category 3 and 4 velodromes.

(text modified on 1.01.02).

ACCOMMODATION FOR OFFICIALS

Finish judge's podium

3.6.091 A podium must be provided for the judge at the finish, located in the track centre in line with the finish line.

Box for the Commissaires Panel

3.6.092 Adequate accommodation must be provided for the commissaires on the track centre adjacent to the finish line.

(text modified on 1.01.02).

Box for the referee:

3.6.093 Provision must be provided for the judge-referee on the outside of the track. It must be in a quiet, isolated location overlooking the track with an unimpeded view, e.g. at the top of the stand above the finish line. During competitions there must be a radio link between the referee and the other commissaires, including the starter and the president of the Commissaires Panel.

Category 1 and 2 velodromes must also provide the referee with a video filming system with slow-motion replay which enables all the shots of the race to be reviewed.

Centre podium for the starter:

3.6.093 bis In the middle of the track center in line with the pursuit lines, a podium must be provided for the starter. It must have an area of between 3 and 4 m² and must be raised above track level.

(text modified on 1.01.02).

UCI CYCLING REGULATIONS

HOMOLOGATION OF VELODROMES

3.6.094 At the time of their homologation, velodromes shall be classified into four categories on the basis of the technical quality of the track and installations. The category determines the level of competition which can be organised in the velodrome, as shown in the following table:

CATEGORY	HOMOLOGATION	LEVEL OF EVENTS
1	UCI	Elite World Championships and Olympic Games.
2	UCI	World Cups Continental Championships World Junior Championships
3	UCI	Other international events
4	NATIONAL FEDERATION	National events

3.6.095 Categories 1 and 2 tracks must meet the following criteria (calculated for maximum safe speeds in the range 85 km/h up to 110 km/h):

Length of the track	250 m	285.714 m	333.33 m	400 m
Radius of bends	19-25 m	22-28 m	25-35 m	28-50 m
Width	7-8 m	7-8 m	7-9 m	7-10 m

Other tracks must be designed to guarantee a minimum safe speed of at least 75 km/h.

(text modified on 1.01.02).

3.6.096 Requests for homologation shall be submitted to the UCI by the national federation of the country in which the velodrome is located.

3.6.097 The request for homologation must be sent to the UCI at least 2 months before the planned inspection date. It must be accompanied by a technical file complying with the UCI's standard model.

The UCI may require any additional document or information.

(text modified on 1.01.02).

3.6.098 The national federation shall organise the inspection of the velodrome in the presence of a specialist responsible for carrying out the regulation measurements under the direction of a UCI delegate. On this occasion a test of the track by a group of riders must be carried out.

All expenses incurred in connection with the inspection of the velodrome are to be covered by the applicant, the national federation being held jointly liable.

UCI CYCLING REGULATIONS

The costs of the UCI delegate are covered in accordance with the conditions specified in the UCI financial obligations in force.

(text modified on 1.01.02).

3.6.099 A detailed inspection report shall be drawn up by the UCI delegate and countersigned by the persons responsible for the measurement of the track and a representative of the national federation.

3.6.100 Should the UCI consider that there are aspects which might lead to homologation being withheld, it shall invite the parties requesting homologation to justify these aspects before a decision is reached. Failing this, and in the event that homologation for the velodrome is withheld, the Federation concerned may appeal to the Appeals Board.

3.6.101 Any changes to or renovation of the facilities following the inspection of the velodrome shall nullify the homologation. New homologation is subject to the procedure described in articles 3.6.097 and following.

(text modified on 1.01.02).

VII

Chapter TRACK TEAMS

[chapter introduced on 31.05.04].

§ 1 Identity

3.7.001 A Track Team (TT) is an entity, comprising at least one (1) rider and its employer, set up for the purpose of participating in international track events.

3.7.002 The Team shall comprise all the riders employed by the same employer, the employer itself, the sponsors and all the other persons contracted by the employer and/or the sponsors for the functioning of the team (Team Manager, Coach, Soigneur, Mechanic etc.). It shall be designated by a special name and be registered with the UCI as provided in these regulations.

3.7.003 The track teams may take part in the following speciality events:

- Sprint
- Keirin
- 1000/500 m time trial
- Team sprint
- Individual pursuit
- Points race
- Scratch
- Madison
- Team pursuit

UCI CYCLING REGULATIONS

- 3.7.004** Sponsors shall be persons, companies or bodies which contribute to the funding of the Team. Of these sponsors, no more than two may be designated as the principal partners of the Team. Should neither of the two principal partners be the employer of the team then the employer may be only a person or body corporate, whose sole commercial income is derived from advertising.
- 3.7.005** The principal partner(s) and the employer shall commit themselves to the Team for a whole number of calendar years.
- 3.7.006** The name of the Team shall be that of the company or brand name of the principal partner or that of one of both, or the two principal partners.
- 3.7.007** No two Teams, their principal partners or employers, may bear the same name. Should application for a new and identical name be simultaneously made by two or more Teams, priority shall be given to the Team which has used the name for the longer or longest time.
- 3.7.008** The Team must be affiliated to the national federation, member of the UCI, of the nationality of the majority of its riders. In the interest of the development of track cycling, the management committee may grant a special dispensation to this rule.

§ 2 Legal and Financial Status

- 3.7.009** The employer of riders forming a Team shall be a person(s)/corporation(s) legally entitled to engage personnel. It shall sign contracts with the riders.
- 3.7.010** The principal Partner(s) of the Team, other than the employer, shall be held jointly and knowingly severally liable for the payment of 3 months salary in case of default by the employer as well as the financial obligations chargeable to the team, towards the UCI and the national federations, fines included.

§ 3 Registration with UCI

- 3.7.011** Each year, Teams must register with the Union Cycliste Internationale.
- 3.7.012** Teams shall, at the same time, register their riders.
- 3.7.013** Teams shall communicate their list of staff and riders prior to 15 days after the UCI track individual classification period start, for verification and registration.

On the list for each Team the following must be indicated:

1. the exact name of the Team.
2. the detailed contact details (address, e-mail, telephone and fax numbers) to which all communications for the Team can be sent.
3. the names and addresses of the principal partners, the employer, the Team Manager and the Assistant Team Manager

UCI CYCLING REGULATIONS

4. the surnames, first names, addresses, nationalities and dates of birth of the riders, the dates and numbers of their licences and the authority that issued them.
5. Copies of contracts between the TTT and the respective riders.

3.7.014 Article 3.7.013 shall also apply to any amendment to the list. Such amendments shall immediately be submitted by the Teams to the UCI for approval.

3.7.015 Only Teams on the registered list of the UCI may receive benefits such as those listed in article 3.7.019.

3.7.016 By their annual registration with the UCI, Teams and especially the employers and sponsors shall undertake to respect the Constitution and Regulations of the UCI and their respective National Federation and to participate in cycling events in a loyal and sporting manner. The employer and principal partners shall be held jointly and severally liable for all the financial commitments of the Team to the UCI and the National Federations, including any relevant fines.

3.7.017 The registration of the Team with the UCI shall involve a registration fee that the Team shall pay prior to 1 month after the current UCI track individual classification period start. The amount shall be set annually by the UCI Management Committee.

3.7.018 With their registration application, each team must submit to the UCI a colour graphic design of their Team jersey, complete with sponsor logos.

3.7.019 Those Teams registered with the UCI will receive the following benefits:

1. Inclusion on the UCI Track Team Ranking.
2. Information services and publications in addition to the regular distributions.
3. Direct entry services for major UCI events.
4. Preferred pricing, where negotiated, for accommodations and food at World Cup events.

§ 4 Teams and Riders

3.7.020 The team shall be the totality of track team riders to take part in events as specified in article 3.7.003.

3.7.021 The total number of riders per Team shall not be greater than 10.

3.7.022 A rider shall not enter into any commitment with an organiser, whomsoever that organiser may be, with a view to participating in a race, without having firstly obtained the agreement of his employer or of the employer's delegate. That agreement shall be considered to have been granted if, on being duly requested, the employer has not replied within ten days.

UCI CYCLING REGULATIONS

§ 5 Contract of Employment

- 3.7.023** A rider's membership of a Team shall be subject to a contract which must at least contain the stipulations of the standard contract presented in article 3.7.029. It does not include bonus/incentive programs, race schedules, equipment provisions and other details. These are subject to negotiations between the employer and the rider(s).
- 3.7.024** Any clause concluded between the rider and the employer that clearly impinges on the basic rights of the rider as provided for in the UCI regulations shall be considered null and void.
- 3.7.025** Any contract between a Team and a rider shall be drawn up in triplicate at least. One original copy shall be forwarded to the UCI.

§ 6 End of Contract

- 3.7.026** On the expiration of the foreseen term of the contract, the rider shall be free to enter the service of some other employer. No system of transfer fees shall be permitted.

§ 7 Dissolution of a Track Team

- 3.7.027** A Track Team shall announce its dissolution or the end of its activity or its inability to respect its obligations, as soon as possible to the riders, to its other members, to the UCI and its National Federation.

Once this announcement has been made, riders shall be fully entitled to contract with third parties for the following season or for the period starting at the moment announced for the dissolution, the end of activities or the inability to perform.

§ 8 Penalties

- 3.7.028** Should a Team, as a whole, fail or cease to meet all the conditions of the relevant UCI regulations, it may no longer participate in cycling events.

UCI CYCLING REGULATIONS

§ 9 UCI Model Contract Between a Rider and a Track Team

3.7.029 Between the undersigned,

(name and address of employer)

employer of the **Track** Team (name of the **Track** Team), affiliated by the (name of the National Federation) and whose principal partners are:

1. (name and address) (if appropriate, the employer)
2. (name and address)

hereafter called «the Employer»,

ON ONE PART

And: (name and address of the rider)

born in on

nationality

holder of a licence issued by

hereafter called «the Rider»

ON THE OTHER PART

Do hereby recall that:

- The Employer employs a team of cyclists who, forming the (name of **the** Team) and under the direction of Mr. (name of the Team Manager), participate in track events governed by the Regulations of the International Cycling Union;
- The Rider wishes to join the (name of the Team)
- Both parties are acquainted with and declare that they will abide wholly by the UCI Constitution and Regulations, and those of its affiliated National Federation.

This having been established, it is hereby agreed as follows:

ARTICLE 1 - Engagement

The Employer shall engage the Rider, and the Rider shall agree to be engaged as a Track rider.

The participation of the Rider in events in other disciplines shall be agreed upon by the Parties case by case.

UCI CYCLING REGULATIONS

ARTICLE 2 - Duration

The present contract shall be concluded for a fixed period commencing on.... and expiring on....

ARTICLE 3 - Remuneration

The Rider shall be entitled to an annual gross salary of.... This remuneration may not be lower than the legal minimum wage or, where there is no legal minimum, than the usual salary that is paid or should be paid to full-time workers employed in the country whose National Federation issued the Rider's licence or in the country where the Team has its head office, whichever the higher.

If the duration of that contract is to be less than one year, the Rider shall, over that period, earn at least the full annual salary provided for in the preceding paragraph, less the contractual salary that he would have been able to earn, as a rider with professional status, with some other employer in the course of the year preceding the final date of the present contract.

This provision shall not apply if the present contract is extended.

ARTICLE 4 - Payment of remuneration

1. The Employer shall pay the salary referred to in article 3 above in at least four instalments, at the latest on the last working day of each three-month period.
2. Should the Rider be suspended under the terms of the UCI Regulations or those of one of its affiliate Federations, he/she shall not be entitled to the said remuneration referred to in article 3 for the part of the suspension exceeding one month.
3. Should the Employer fail to pay to the net the remuneration referred to in article 3, the Rider shall, without summoning the Employer to make payment, be fully entitled to the following extra benefits:
 - (a) 5% interest for each of the five working days in arrears starting with the fourth day,
 - (b) and thereafter, an 1% interest for each weekday.The total increase may not exceed 50% the amount due.

ARTICLE 5 - Insurance

The employer shall provide the rider with an appropriate insurance to ensure a reasonable allowance in the event of an unforeseen injury or illness which affects the rider's ability to fulfil the competition aspects of his/her contractual obligations.

ARTICLE 6 - Premiums and prizes

The Rider shall be entitled to premiums and prizes won during cycling competitions in which he/she participated for the Team, in accordance with the Regulations of the UCI and its Affiliated Federations. Premiums and prizes shall be paid as promptly as possible, but at latest on the last working day of the month following that in which said premiums and prizes were won.

ARTICLE 7 - Miscellaneous Obligations

1. The Rider may not, for the duration of the present contract, work for any other **Track** Team or advertise for any other sponsors than those belonging to the (name of **the** Team), except in such cases as are provided for in the Regulations of the UCI and of its affiliated Federation.
2. The Employer hereby undertakes to allow the Rider properly to perform his occupation by providing him with the necessary equipment and apparel and by permitting him/her to participate in a sufficient number of cycling events, either as a member of the team or individually.

UCI CYCLING REGULATIONS

- The Rider may not participate individually in a race without the express agreement of the Employer. The Employer shall be deemed to have given its agreement if it has not replied within a period of ten days from the date of the request. In no case may the Rider take part in a race within any other structure or a mixed team if the (name of the Team) has already entered for that race.

In case of a national selection, the Employer shall be required to permit the Rider to participate in preparatory races and programmes decided upon by the National Federation. The Employer shall authorise the National Federation to give the Rider any instructions it deems necessary in connection with and for the duration of the selection provided that it does so solely in connection with sporting matters, in its own name and on its own behalf.

In none of the aforementioned cases shall the Contract be suspended.

ARTICLE 8 - Transfers

On the expiry of the present contract, the Rider shall be entirely free to sign a new contract with another employer, subject to the provisions of the UCI Regulations.

ARTICLE 9 - End of contract

Notwithstanding the legislation governing the present contract, it may terminate before expiration, in the following cases and on the following conditions:

- The Rider may terminate the present contract, without notice nor liability for damages:
 - if the employer be declared bankrupt, insolvent or goes into liquidation.
 - if the employer or a principal partner withdraw from the Team and the continuity of the Team is not guaranteed or else if the Team announces its dissolution, the winding up of its activities or its inability to meet its commitments; if the announcement be made for a given date, the Rider shall perform the contract until that date.
- The Employer may terminate the present contract, without notice or liability for damages, in the case of serious defaulter on the part of the Rider and of the suspension of the Rider under the terms of the UCI Regulations for the duration of the present contract remaining to run. Serious defaulter is considered, in particular, refusal to participate in cycling races, despite being constantly summoned to do so by the Employer.
If need be, the Rider shall have to prove that he was in no state to participate in a race.
- Either party shall be entitled to terminate the present contract, without notice or liability, should the Rider be rendered permanently unable to exercise the occupation of professional cyclist.

ARTICLE 10 - Unreasonable demand

Any clause agreed upon between the parties that runs counter to the terms of the UCI Model Contract between a rider and a Team and/or to the provisions of the UCI Constitution or Regulations and which would in any way restrict the rights of the Rider shall be null and void.

ARTICLE 11 - Arbitration

Any dispute between the Parties arising from the present Contract shall be submitted to arbitration, to the exclusion of the courts, by the UCI Disciplinary Commission.

Made in _____ on _____

UCI CYCLING REGULATIONS

in as many copies as required by the legislation applicable to the present contract, that is to say,.... plus one copy to be sent to the UCI.

The Rider

The Employer

Approved for joint and several liability for three (3) months salary payment

Principal Partner
of the **Track** Team

Principal Partner
of the **Track** Team

VIII

Chapter CALENDAR

General observations

3.8.001 Track events are entered on the calendars in accordance with their classification and criterias as per articles 3.8.003 and 3.8.005.

The UCI Management Committee allocate a classification in the international calendar to each event in accordance with the criteria which it shall draw up, taking into account the criterias set in article 3.8.003.

(text introduced on 1.01.04).

3.8.002 Without prejudice to the provisions of article 1.2.014, if an event registered in one of the classes 1 to 3 as specified by article 3.8.003 is not run **without UCI clearance**, it shall be relegated to the next lower class for the following year, unless it is already in class 4.

(text modified on 1.01.04; 26.08.04).

World Calendar

3.8.003 Type of event	Criterias
Olympic Games	- As per the regulations for cycling events at the Olympic Games
World Championships	- As per World Championships regulations
World Cup legs	- As per articles 3.4.004 to 3.4.007
Continental Championships	- See article 3.8.004
Regional Games	
Class 1	- Minimum 6 participating nations - Events for Men Elite - Events for: Junior (M/W), U23 (M/W) or Women Elite (Minimum 3 categories) - Minimum 5 competitions*

UCI CYCLING REGULATIONS

Class 2	<ul style="list-style-type: none"> - Minimum 5 participating nations - Events for Men Elite - Events for: Junior (M/W), U23 (M/W) or Women Elite (Minimum 2 categories) - Minimum 3 competitions*
Class 3	<ul style="list-style-type: none"> - Minimum 4 participating nations - Events for Men Elite - Events for: Junior (M/W), U23 (M/W) or Women Elite (Minimum 1 categories) - Minimum 2 competitions*
Class 4	<ul style="list-style-type: none"> - Minimum 4 participating nations

* Competition = event from the Elite World Championships programme, organised in a category.

(text introduced on 1.01.04).

3.8.004 To be able to be registered on the International Calendar, the Continental Championships have to guarantee participation of riders of at least 6 federations of that continent, exception being where the Continental Confederation does not have 6 federations.

(text introduced on 1.01.04).

National Calendars

3.8.005	Type of event	Participation
	National Championships	Governed by National Federations
	Other events	Governed by National Federations

(text introduced on 1.01.04).

UCI CYCLING REGULATIONS

(Appendix 1)

**UCI
REQUEST OF WORLD RECORD HOMOLOGATION**

Date of the performance:
 Date of the request sent to UCI:
 (The request SHALL REACH the UCI no later than 1 month after the performance - Immediate notification by fax to UCI)
 Secretary General of National Federation:

VELODROME

Location of Track (City):
 Track Measurement.....metres.....Material.....(wood etc.)
 Covered or Open:.....
 UCI Homologation Date:

INFORMATION for PROCESSING

Request of World Record Homologation for:.....
 (Men - Women - Junior Men - Junior Women)

Distance :
 Start(standing or flying):.....
 Date of attempt:.....Result:
 Complete name of the rider:.....Nationality:.....
 (Family) (Given)

Result of Doping Control:
 Time of the attempt:
 During an event / Special Attempt:.....
 Resume of record:.....

Attestation of the result by Officials

We, the undersigned officials confirm that the record information as set out within this document was achieved according to the UCI Regulation.

Position	Name(family)	Given Name	Signature
UCI Delegate			
UCI International Commissaires			
Official Timekeepers			
(manual)			
(electronic)			
Anti-doping Inspector			

To be enclosed – Print out electronic timing slips
 – Doping control formular

Place and date.....
 UCI International Commissaire Signature:

NB: This document is established in accordance with the world records regulations.